

N

WATERPROOFING OPERATIONS USING SYNTHETIC MEMBRANES

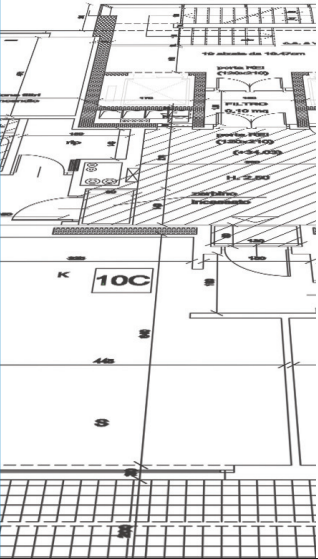

N specifications of **WATERPROOFING OPERATIONS USING SYNTHETIC MEMBRANES**

N.1 PREPARATION OF THE SUBSTRATE

N.1.1 INSTALLATION AND PREPARATION OF FLAT ROOFS

Procedure

N.2 WATERPROOFING SYSTEMS FOR FLAT ROOFS BALLASTED WITH GRAVEL

N.2.1 FLAT ROOFS BALLASTED WITH GRAVEL - COLD-ROOF SYSTEM

Procedure

N.2.2 WATERPROOFING SYSTEMS FOR FLAT ROOFS BALLASTED WITH GRAVEL

Procedure

N.3 WATERPROOFING SYSTEMS FOR FLAT ROOFS BALLASTED WITH CEMENT SLABS ON SUPPORTS (SUITABLE FOR FOOT TRAFFIC)

N.3.1 WATERPROOFING SYSTEM FOR FLAT ROOFS BALLASTED WITH CEMENT SLABS ON SUPPORTS - COLD-ROOF SYSTEM

Procedure

N.3.2 WATERPROOFING SYSTEMS FOR FLAT ROOFS BALLASTED WITH CEMENT SLABS ON SUPPORTS - WARM-ROOF SYSTEM

Procedure

N.4 WATERPROOFING SYSTEMS FOR FLAT ROOFS BALLASTED WITH BONDED TILES (SUITABLE FOR FOOT TRAFFIC)

N.4.1 WATERPROOFING SYSTEMS FOR FLAT ROOFS BALLASTED WITH BONDED TILES - COLD-ROOF SYSTEM

Procedure

N.4.2 WATERPROOFING SYSTEMS FOR FLAT ROOFS BALLASTED WITH BONDED TILES - WARM-ROOF SYSTEM

Procedure

N.5 WATERPROOFING SYSTEMS FOR FLAT ROOFS BALLASTED WITH A CONCRETE SCREED (SUITABLE FOR FOOT/VEHICULAR TRAFFIC)

N.5.1 WATERPROOFING SYSTEMS FOR FLAT ROOFS BALLASTED WITH A CONCRETE SCREED - COLD-ROOF SYSTEM

Procedure

N.5.2 WATERPROOFING SYSTEMS FOR FLAT ROOFS BALLASTED WITH A CONCRETE SCREED - WARM-ROOF SYSTEM

Procedure

N.6 WATERPROOFING SYSTEMS FOR FLAT ROOFS BALLASTED WITH SOIL (GREEN ROOFS/ROOF GARDENS)

N.6.1 WATERPROOFING SYSTEMS FOR FLAT ROOFS BALLASTED WITH SOIL - COLD-ROOF SYSTEM

Procedure

- N.6.2** **WATERPROOFING SYSTEMS FOR FLAT ROOFS BALLASTED WITH SOIL - WARM-ROOF SYSTEM**
Procedure
- N.7** ***ADHERED WATERPROOFING SYSTEMS FOR EXPOSED FLAT ROOFS***
- N.7.1** **ADHERED WATERPROOFING SYSTEMS FOR EXPOSED FLAT ROOFS - COLD-ROOF SYSTEM**
Procedure
- N.7.2** **ADHERED WATERPROOFING SYSTEMS FOR EXPOSED FLAT ROOFS - WARM-ROOF SYSTEM**
Procedure
- N.8** ***MECHANICALLY-FIXED WATERPROOFING SYSTEMS FOR EXPOSED FLAT ROOFS***
- N.8.1** **MECHANICALLY-FIXED WATERPROOFING SYSTEMS FOR EXPOSED FLAT ROOFS - COLD-ROOF SYSTEM**
Procedure
- N.8.2** **MECHANICALLY-FIXED WATERPROOFING SYSTEMS FOR EXPOSED FLAT ROOFS - WARM-ROOF SYSTEM ON A REINFORCED CEMENT SLAB**
Procedure
- N.8.3** **MECHANICALLY-FIXED WATERPROOFING SYSTEMS FOR EXPOSED FLAT ROOFS - WARM-ROOF SYSTEM ON CORRUGATED STEEL SHEET**
Procedure
- N.8.4** **MECHANICALLY-FIXED WATERPROOFING SYSTEMS FOR EXPOSED FLAT ROOFS - WARM-ROOF SYSTEM ON WOODEN FLOOR BOARDS**
Procedure
- N.9** ***STANDARD ACCESSORY PARTS AND DETAILS***
- N.9.1** **ROOF EDGING**
Procedure
- N.9.2** **WALL FILLETS**
Procedure
- N.9.3** **DRAINAGE OUTLETS**
Procedure

N.1 PREPARATION OF THE SUBSTRATE

N.1.1 INSTALLATION AND PREPARATION OF FLAT ROOFS Procedure

Before installing a waterproofing system made from a synthetic membrane, the roof must be installed and/or checked to make sure it is suitable for use and that it has been prepared correctly.

Reinforced cement and concrete-masonry flat roofs

Reinforced cement and concrete-masonry flat roofs must be dimensioned to withstand the design loads and overloads, and a cement levelling layer must be applied to form a slope.

To make the substrate suitable for applying the system, the following must be carried out:

- horizontal surfaces must be prepared correctly and levelled;
- vertical surfaces must be prepared correctly and levelled to make them smooth and suitable for applying the various layers of the waterproofing system. If necessary, render the surfaces with cementitious mortar;
- guttering, downpipes, elbows, etc. must be installed;
- all surfaces to be coated must be thoroughly cleaned.

The substrate, therefore, must be smooth, clean and dry and all corners and edges must be smoothed.

To guarantee a good hold for the mechanical fixing system used to install insulation panels and/or the waterproof membrane, the anchorage substrate must have the following minimum requirements:

- compressive strength $\geq 25 \text{ N/mm}^2$;
- minimum thickness 50 mm.

If in doubt, we recommend carrying out preliminary pull-out tests directly on site.

Corrugated carbon steel sheet flat roofs

Corrugated carbon steel sheet flat roofs must be dimensioned to withstand the design loads and overloads.

To make the substrate suitable for applying the waterproofing system, the following must be carried out:

- make sure there is continuity between the corrugated sheets and the installation surface. Continuity is guaranteed by using press-formed steel sheet or other suitable means around edges and protruding elements;
- horizontal surfaces must be prepared correctly and levelled;
- vertical surfaces must be prepared correctly and levelled to make them smooth and suitable for applying the various layers of the waterproofing system;
- guttering, downpipes, elbows, etc. must be installed;
- remove all burrs and sharp edges from the corrugated sheets;
- all surfaces to be coated must be thoroughly cleaned.

The substrate, therefore, must be smooth, clean and dry and all corners and edges must be smoothed.

To guarantee a good hold for the mechanical fixing system used to install insulation panels and/or the waterproof membrane, the anchorage substrate must have the following minimum requirements:

- corrugated sheet in carbon steel;
- minimum thickness 0.7 mm.

If in doubt, we recommend carrying out preliminary pull-out tests directly on site.

Wooden decking flat roofs

Wooden decking flat roofs must be dimensioned to withstand the design loads and overloads.

The wooden decking may be made from planks of deal perfectly butted together, beaded birch planks, plywood panels or oriented strand board (OSB). To fix the planks and/or panels for the decking in place to the load-bearing structure and prevent them warping, use special wood screws or deformed shank nails. Fixing the planks or panels in place with traditional nails is not recommended.

To make the substrate suitable for applying the waterproofing system, the following must be carried out:

- make sure there is continuity between the wooden decking and the installation surface. Continuity is guaranteed by using press-formed steel sheet or other suitable means around edges and protruding elements;
- horizontal surfaces must be prepared correctly and levelled;
- vertical surfaces must be prepared correctly and levelled to make them smooth and suitable for applying the various layers of the waterproofing system;
- guttering, downpipes, elbows, etc. must be installed;
- all surfaces to be coated must be thoroughly cleaned.

The substrate, therefore, must be smooth, clean and dry and all corners and edges must be smoothed.

To guarantee a good hold for the mechanical fixing system used to install insulation panels and/or the waterproof membrane, the anchorage substrate must have the following minimum requirements:

- wooden planks must be homogeneous and compact, minimum thickness 21 mm;
- minimum thickness of plywood planks 18 mm;
- minimum thickness of oriented strand board (OSB) planks 18 mm.

If in doubt, we recommend carrying out preliminary pull-out tests directly on site.

N.2 WATERPROOFING SYSTEMS FOR FLAT ROOFS BALLASTED WITH GRAVEL

N.2.1 FLAT ROOFS BALLASTED WITH GRAVEL - COLD-ROOF SYSTEM Procedure

Preparation of the substrate

Installation and/or checking of reinforced concrete or concrete-masonry substrates with a suitable cement levelling layer to form a slope (see section [N.1.1](#)).

When handed over, substrates must be smooth, clean and dry and all corners and edges must be smooth.

Application of the compensation and levelling layer

Loose-laid **Polydren 500 PP** 100% polypropylene non-woven, needle-punched fabric with a weight of 500 g/m², with overlaps approximately 10 cm wide between adjacent sheets (see section [N.2.1.1](#)).

Application of the waterproof membrane

PVC-P Membranes

- Loose-laid **Mapeplan B 15** 1.5 mm-thick, UV-resistant and weather-resistant synthetic membrane in PVC-P, reinforced with dimensionally-stable glass mat, specifically formulated to resist macrobiological attack and bacteria, laid with overlaps approximately 8 cm wide between adjacent sheets (see section [N.2.1.2](#)).
- Or, loose-laid **Mapeplan B 18** 1.8 mm-thick, UV-resistant and weather-resistant synthetic membrane in PVC-P, reinforced with dimensionally-stable glass mat, specifically formulated to resist macrobiological attack and bacteria, laid with overlaps approximately 8 cm wide between adjacent sheets (see section [N.2.1.3](#)).

Heat-weld the overlaps with a manual and automatic hot-air welder after cleaning them with Mapeplan Cleaner.

Carry out manual heat-welding by spot-welding, internal pre-welding and final external welding to form a weathertight seal.

Flexible Polyolefin (TPO/FPO) membranes

- Loose-laid **Mapeplan T B 15** 1.5 mm-thick, UV-resistant and weather-resistant synthetic waterproof membrane in flexible Polyolefin (TPO/FPO) reinforced with dimensionally-stable glass mat, with a high-reflectance, Smart White surface, laid with overlaps approximately 8 cm wide between adjacent sheets (see section [N.2.1.4](#)).
- Or, loose-laid **Mapeplan T B 18** 1.8 mm-thick, UV-resistant and weather-resistant synthetic waterproof membrane in flexible Polyolefin (TPO/FPO) reinforced with dimensionally-stable glass mat, with a high-reflectance, Smart White surface, laid with overlaps approximately 8 cm wide between adjacent sheets (see section [N.2.1.5](#)).

Heat-weld the overlaps with a manual and automatic hot-air welder after cleaning them with Mapeplan T Cleaner.

Carry out manual heat-welding by spot-welding, internal pre-welding and final external welding to form a weathertight seal.

Vertical turn-ups**PVC-P membranes**

Vertical turn-ups for waterproof membranes around the edges of roofs, wall fillets, mass fillets, skylights, etc. using:

- **Mapeplan B 15** 1.5 mm-thick, UV-resistant and weather-resistant membrane in PVC-P reinforced with dimensionally-stable glass mat (see section **N.2.1.6**) for 1.5 mm thick waterproof membranes;
- **Mapeplan B 18** 1.8 mm-thick, UV-resistant and weather-resistant membrane in PVC-P reinforced with dimensionally-stable glass mat (see section **N.2.1.7**) for 1.8 mm thick waterproof membranes.

Fully-bond the turn-ups to the substrate using **Mapeplan ADS 200**, a specific contact adhesive.

Heat-weld the turn-ups to the membrane with a manual and automatic hot-air welder after cleaning them with Mapeplan Cleaner.

Carry out manual heat-welding by spot-welding, internal pre-welding and final external welding to form a weathertight seal.

Flexible Polyolefin (TPO/FPO) membranes

Vertical turn-ups for waterproof membranes around the edges of roofs, wall fillets, mass fillets, skylights, etc. using:

- **Mapeplan T B 15** 1.5 mm-thick, UV-resistant and weather-resistant membrane in flexible polyolefin (TPO/FPO) reinforced with dimensionally-stable glass mat, with a high-reflectance, Smart White surface (see section **N.2.1.8**) for 1.5 mm thick waterproof membranes.
- **Mapeplan T B 18** 1.8 mm-thick, UV-resistant and weather-resistant membrane in flexible Polyolefin (TPO/FPO) reinforced with dimensionally-stable glass mat, with a high-reflectance, Smart White surface (see section **N.2.1.9**) for 1.8 mm thick waterproof membranes.

Fully-bond the turn-ups to the substrate using **Mapeplan ADS 300**, a specific contact adhesive.

Heat-weld the turn-ups to the membrane with a manual and automatic hot-air welder after cleaning them with Mapeplan T Cleaner.

Carry out manual heat-welding by spot-welding, internal pre-welding and final external welding to form a weathertight seal.

Perimeter mechanical fixing system

A linear perimeter fixing system is applied to prevent loose-laid waterproof membranes from moving or being dragged due to variations in temperature, substrate deformation or deformations/movements of the insulation panels or underlying materials.

The fixing system (see section **N.2.1.10**) is applied around the perimeter of the roof, skylights, chimney stacks, wall fillets, etc. and fillets between horizontal and vertical surfaces, and comprises:

- Mapeplan Metalbar pre-punched, zinc-plated, carbon steel profiled fastening bars;
- Fasteners suitable for the type of substrate (at least 4 fasteners per metre);
- 4 mm-diameter, anti-tear seaming cord applied around the Mapeplan Metalbar profiles by hot-air welding to the Mapeplan waterproof membrane.

Application of the protection layer

Loose-laid **Polydren 500 PP** protection layer in 100% polypropylene non-woven, needle-punched fabric with a weight of 500 g/m², with overlaps approximately 10 cm wide between adjacent sheets (see section **N.2.1.11**).

Application of the ballast layer

Application of a layer of ballast to counteract the suction effect of wind, made from washed, round gravel with a grain size of 16 to 32 mm (see section **N.2.1.12**). Apply an even layer at least 50 mm thick. Apply the layer of ballast carefully to avoid damaging the underlying waterproofing layer.



N.2 WATERPROOFING SYSTEMS FOR FLAT ROOFS BALLASTED WITH GRAVEL

N.2.1.1 Application of non-woven fabric to form the compensation and levelling layer

Supply and application of a compensation and levelling layer made from 100% polypropylene non-woven, needle-punched fabric with a weight of 500 g/m² (such as **Polydren 500 PP** produced by POLYGLASS S.p.A.).

The product must have the following characteristics:

average tensile strength according to EN ISO 10319:	12 (-13%) kN/m
average elongation at maximum load according to EN ISO 10319:	> 50%
static puncture resistance CBR according to EN ISO 12236:	1.5 (-10%) kN
mass per unit area according to EN ISO 9864:	500 (-10%) g/m ²
flow capacity normal to the surface according to EN ISO 11058:	35 (-30%) l/m ² s

Loose-lay the product and overlap the edges of adjacent sheets by approximately 10 cm.

Included and calculated in the price for work carried out according to specification:

– per square metre(€/m²)

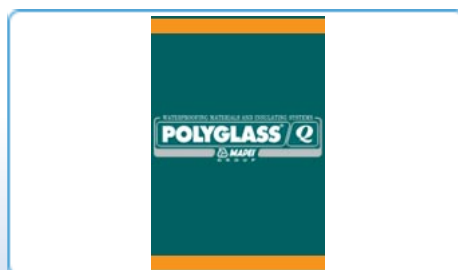

N.2 WATERPROOFING SYSTEMS FOR FLAT ROOFS BALLASTED WITH GRAVEL

N.2.1.2 Application of 1.5 mm-thick synthetic waterproof membrane in PVC-P

Supply and application of UV-resistant and weather-resistant synthetic waterproof membrane in PVC-P reinforced with dimensionally-stable glass mat (such as **Mapeplan B 15** produced by POLYGLASS S.p.A.), specifically formulated to resist macrobiological attack and bacteria. The membrane must be produced by “multi-extrusion coating”, a single-step production process which allows the internal reinforcement to be inserted without pre-lamination, and must have a product certificate and marked with the CE symbol in compliance with EN 13956 standards. The effective thickness must be at least 1.5 mm (-5/+10%) according to EN 1849-2 standards.

The product must also have the following characteristics:

visible defects according to EN 1850-2:	none
straightness according to EN 1848-2:	≤ 30 mm
flatness according to EN 1848-2:	≤ 10 mm
mass per unit area according to EN 1849-2:	1.8 kg/m ² (-5/+10%)
impermeability to water according to EN 1928:	≥ 400 kPa/72h
reaction to fire according to EN 13501-1:	Euroclass E
peel strength of welds according to EN 12316-2:	≥ 300 N/50 mm
shear strength of welds according to EN 12317-2:	≥ 500 N/50 mm
vapour diffusion resistance according to EN 1931:	μ 19,000
tensile strength according to EN 12311-2:	≥ 9 N/mm ²
elongation at failure according to EN 12311-2:	≥ 200%
impact resistance according to EN 12691:	method A ≥ 600 mm
impact resistance according to EN 12691:	method B ≥ 850 mm
static puncture resistance CBR according to EN 12730-B:	≥ 20 kg
tear strength according to EN 12310-2:	≥ 100 N
dimensional stability according to EN 1107-2:	≤ 0.2%
foldability at low temperatures according to EN 495-5:	≤ -25 °C
resistance to UV rays according to EN 1297:	compliant: class 0
resistance to root penetration according to EN 13948:	compliant
production certified according to ISO 9001 and ISO 14001 standards.	

The membrane must be formulated specifically for application in covered, stratigraphic layers subject to the action of microorganisms, bacteria and roots. Loose-lay the membrane, overlap the edges of adjacent sheets by approximately 8 cm and apply a layer of ballast to counteract the suction effect of wind. Heat-weld the overlaps using a manual and automatic hot-air welder after cleaning them with a specific cleaning product (such as Mapeplan Cleaner produced by POLYGLASS S.p.A.).

Carry out manual heat-welding by spot-welding, internal pre-welding and final external welding to form a weathertight seal.

Included and calculated in the price for work carried out according to specification:

– per square metre

.....(€/m²)

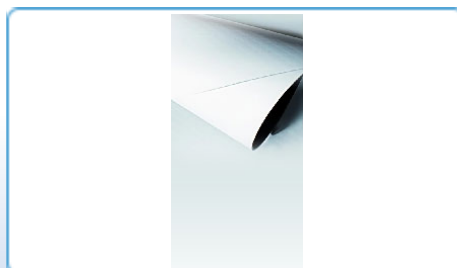

N.2 WATERPROOFING SYSTEMS FOR FLAT ROOFS BALLASTED WITH GRAVEL

N.2.1.3 Application of 1.8 mm-thick synthetic waterproof membrane in PVC-P

Supply and application of UV-resistant and weather-resistant synthetic waterproof membrane in PVC-P reinforced with dimensionally-stable glass mat (such as **Mapeplan B** 18 produced by POLYGLASS S.p.A.), specifically formulated to resist macrobiological attack and bacteria. The membrane must be produced by “multi-extrusion coating”, a single-step production process which allows the internal reinforcement to be inserted without pre-lamination, and must have a product certificate and marked with the CE symbol in compliance with EN 13956 standards.

The effective thickness must be at least 1.8 mm (-5/+10%) according to EN 1849-2 standards.

The product must also have the following characteristics:

visible defects according to EN 1850-2:	none
straightness according to EN 1848-2:	≤ 30 mm
flatness according to EN 1848-2:	≤ 10 mm
mass per unit area according to EN 1849-2:	2.2 kg/m ² (-5/+10%)
impermeability to water according to EN 1928:	≥ 400 kPa/72h
reaction to fire according to EN 13501-1:	Euroclass E
peel strength of welds according to EN 12316-2:	≥ 300 N/50 mm
shear strength of welds according to EN 12317-2:	≥ 500 N/50 mm
vapour diffusion resistance according to EN 1931:	μ 19,000
tensile strength according to EN 12311-2:	≥ 9 N/mm ²
elongation at failure according to EN 12311-2:	≥ 200%
impact resistance according to EN 12691:	method A ≥ 800 mm
impact resistance according to EN 12691:	method B ≥ 950 mm
static puncture resistance CBR according to EN 12730-B:	≥ 20 kg
tear strength according to EN 12310-2:	≥ 100 N
dimensional stability according to EN 1107-2:	≤ 0.2%
foldability at low temperatures according to EN 495-5:	≤ -25 °C
resistance to UV rays according to EN 1297:	compliant: class 0
resistance to root penetration according to EN 13948:	compliant
production certified according to ISO 9001 and ISO 14001 standards.	

The membrane must be formulated specifically for application in covered, stratigraphic layers subject to the action of micro-organisms, bacteria and roots.

Loose-lay the membrane, overlap the edges of adjacent sheets by approximately 8 cm and apply a layer of ballast to counteract the suction effect of wind.

Heat-weld the overlaps using a manual and automatic hot-air welder after cleaning them with a specific cleaning product (such as Mapeplan Cleaner produced by POLYGLASS S.p.A.).

Carry out manual heat-welding by spot-welding, internal pre-welding and final external welding to form a weathertight seal.

Included and calculated in the price for work carried out according to specification:

– per square metre

.....(€/m²)

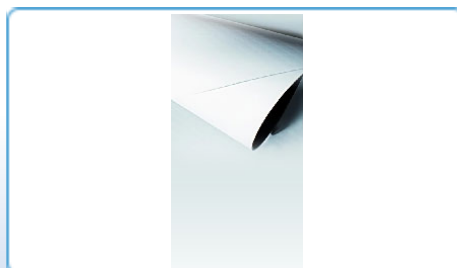

N.2 WATERPROOFING SYSTEMS FOR FLAT ROOFS BALLASTED WITH GRAVEL

N.2.1.4 Application of 1.5 mm-thick synthetic waterproof membrane in flexible polyolefin (TPO/FPO)

Supply and application of UV-resistant and weather-resistant synthetic waterproof membrane in flexible Polyolefin (TPO/FPO) reinforced with dimensionally-stable glass mat, with a high-reflectance, Smart White surface (such as **Mapeplan T B 15** produced by POLYGLASS S.p.A.).

The membrane must be produced by “multi-extrusion coating”, a single-step production process which allows the internal reinforcement to be inserted without pre-lamination, and must have a product certificate and marked with the CE symbol in compliance with EN 13956 standards. The effective thickness must be at least 1.5 mm (-5/+10%) according to EN 1849-2 standards.

The product must also have the following characteristics:

visible defects according to EN 1850-2:	none
straightness according to EN 1848-2:	≤ 30 mm
flatness according to EN 1848-2:	≤ 10 mm
mass per unit area according to EN 1849-2:	1.5 kg/m ² (-5/+10%)
impermeability to water according to EN 1928:	≥ 400 kPa/72h
reaction to fire according to EN 13501-1:	Euroclass E
peel strength of welds according to EN 12316-2:	≥ 300 N/50 mm
shear strength of welds according to EN 12317-2:	≥ 500 N/50 mm
vapour diffusion resistance according to EN 1931:	μ 150,000
tensile strength according to EN 12311-2:	≥ 9 N/mm ²
elongation at failure according to EN 12311-2:	≥ 550%
impact resistance according to EN 12691:	method A ≥ 600 mm
impact resistance according to EN 12691:	method B ≥ 150 mm
static puncture resistance CBR according to EN 12730-B:	≥ 20 kg
tear strength according to EN 12310-2:	≥ 150 N
dimensional stability according to EN 1107-2:	≤ 0.2%
foldability at low temperatures according to EN 495-5:	≤ -35 °C
resistance to UV rays according to EN 1297:	compliant: class 0
resistance to root penetration according to EN 13948:	compliant
production certified according to ISO 9001 and ISO 14001 standards.	

The membrane must have a formulation without plasticisers and volatile organic compounds and must have a low impact on the environment and be eco-compatible.

Loose-lay the membrane, overlap the edges of adjacent sheets by approximately 8 cm and apply a layer of ballast to counteract the suction effect of wind.

Heat-weld the overlaps using a manual and automatic hot-air welder after cleaning them with a specific cleaning product (such as Mapeplan T Cleaner produced by POLYGLASS S.p.A.).

Carry out manual heat-welding by spot-welding, internal pre-welding and final external welding to form a weathertight seal.

Included and calculated in the price for work carried out according to specification:

– per square metre

.....(€/m²)

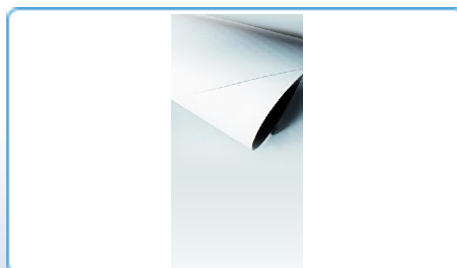

N.2 WATERPROOFING SYSTEMS FOR FLAT ROOFS BALLASTED WITH GRAVEL

N.2.1.5 Application of 1.8 mm-thick synthetic waterproof membrane in flexible polyolefin (TPO/FPO)

Supply and application of UV-resistant and weather-resistant synthetic waterproof membrane in flexible polyolefin (TPO/FPO) reinforced with dimensionally-stable glass mat, with a high-reflectance, Smart White surface (such as **Mapeplan T B** 18 produced by POLYGLASS S.p.A.). The membrane must be produced by “multi-extrusion coating”, a single-step production process which allows the internal reinforcement to be inserted without pre-lamination, and must have a product certificate and marked with the CE symbol in compliance with EN 13956 standards.

The effective thickness must be at least 1.8 mm (-5/+10%) according to EN 1849-2 standards.

The product must also have the following characteristics:

visible defects according to EN 1850-2:	none
straightness according to EN 1848-2:	≤ 30 mm
flatness according to EN 1848-2:	≤ 10 mm
mass per unit area according to EN 1849-2:	1.8 kg/m ² (-5/+10%)
impermeability to water according to EN 1928:	≥ 400 kPa/72h
reaction to fire according to EN 13501-1:	Euroclass E
peel strength of welds according to EN 12316-2:	≥ 300 N/50 mm
shear strength of welds according to EN 12317-2:	≥ 500 N/50 mm
vapour diffusion resistance according to EN 1931:	μ 150,000
tensile strength according to EN 12311-2:	≥ 9 N/mm ²
elongation at failure according to EN 12311-2:	≥ 550%
impact resistance according to EN 12691:	method A ≥ 800 mm
impact resistance according to EN 12691:	method B ≥ 1000 mm
static puncture resistance CBR according to EN 12730-B:	≥ 20 kg
tear strength according to EN 12310-2:	≥ 150 N
dimensional stability according to EN 1107-2:	≤ 0.2%
foldability at low temperatures according to EN 495-5:	≤ -35 °C
resistance to UV rays according to EN 1297:	compliant: class 0
resistance to root penetration according to EN 13948:	compliant
production certified according to ISO 9001 and ISO 14001 standards.	

The membrane must have a formulation without plasticisers and volatile organic compounds and must have a low impact on the environment and be eco-compatible.

Loose-lay the membrane, overlap the edges of adjacent sheets by approximately 8 cm and apply a layer of ballast to counteract the suction effect of wind. Heat-weld the overlaps using a manual and automatic hot-air welder after cleaning them with a specific cleaning product (such as Mapeplan T Cleaner produced by POLYGLASS S.p.A.). Carry out manual heat-welding by spot-welding, internal pre-welding and final external welding to form a weathertight seal.

Included and calculated in the price for work carried out according to specification:

– per square metre

.....(€/m²)

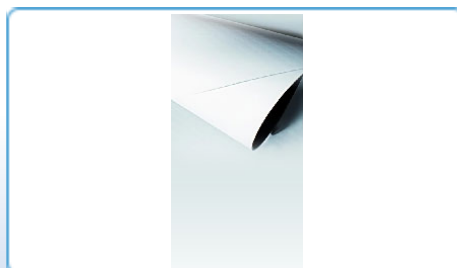

N.2 WATERPROOFING SYSTEMS FOR FLAT ROOFS BALLASTED WITH GRAVEL

N.2.1.6 Vertical turn-ups made from 1.5 mm-thick waterproof membrane in PVC-P

Supply and application of vertical turn-ups for waterproof membranes applied around the edges of roofs, wall fillets, mass fillets, skylights, etc., made from UV-resistant and weather-resistant membrane in PVC-P reinforced with dimensionally-stable glass mat (such as **Mapeplan B 15** produced by POLYGLASS S.p.A.), specifically formulated to resist microbiological attack and bacteria. The material must be produced by “multi-extrusion coating”, a single-step production process which allows the internal reinforcement to be inserted without pre-lamination, and must have a product certificate and marked with the CE symbol in compliance with EN 13956 standards.

The effective thickness must be at least 1.5 mm (-5/+10%) according to EN 1849-2 standards.

Fully-bond the turn-ups to the substrate using a specific contact adhesive (such as **Mapeplan ADS 200** produced by POLYGLASS S.p.A.). Heat-weld the vertical turn-ups to the membrane using a manual and automatic hot-air welder after cleaning it with a specific cleaning product (such as Mapeplan Cleaner produced by POLYGLASS S.p.A.). Carry out manual heat-welding by spot-welding, internal pre-welding and final external welding to form a weathertight seal.

Included and calculated in the price for work carried out according to specification:

– per square metre

.....(€/m²)

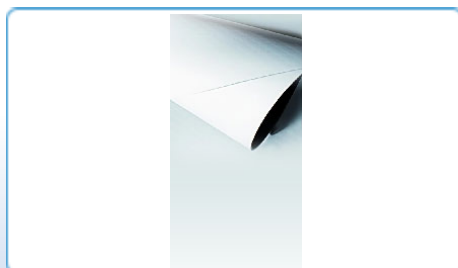

N.2 WATERPROOFING SYSTEMS FOR FLAT ROOFS BALLASTED WITH GRAVEL

N.2.1.7 Vertical turn-ups made from 1.8 mm-thick waterproof membrane in PVC-P

Supply and application of vertical turn-ups for waterproof membranes applied around the edges of roofs, wall fillets, mass fillets, skylights, etc., made from UV-resistant and weather-resistant membrane in PVC-P reinforced with dimensionally-stable glass mat (such as **Mapeplan B 18** produced by POLYGLASS S.p.A.), specifically formulated to resist microbiological attack and bacteria. The material must be produced by “multi-extrusion coating”, a single-step production process which allows the internal reinforcement to be inserted without pre-lamination, and must have a product certificate and marked with the CE symbol in compliance with EN 13956 standards.

The effective thickness must be at least 1.8 mm (-5/+10%) according to EN 1849-2 standards.

Fully-bond the turn-ups to the substrate using a specific contact adhesive (such as **Mapeplan ADS 200** produced by POLYGLASS S.p.A.).

Heat-weld the vertical turn-ups to the membrane using a manual and automatic hot-air welder after cleaning it with a specific cleaning product (such as Mapeplan Cleaner produced by POLYGLASS S.p.A.).

Carry out manual heat-welding by spot-welding, internal pre-welding and final external welding to form a weathertight seal.

Included and calculated in the price for work carried out according to specification:

– per square metre

.....(€/m²)

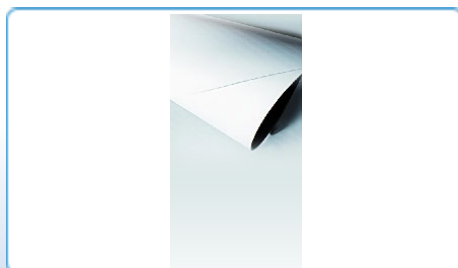

N.2 WATERPROOFING SYSTEMS FOR FLAT ROOFS BALLASTED WITH GRAVEL

N.2.1.8 Vertical turn-ups made from 1.5 mm-thick waterproof membrane in flexible polyolefin (TPO/FPO)

Supply and application of vertical turn-ups for waterproof membranes applied around the edges of roofs, wall fillets, mass fillets, skylights, etc., made from UV-resistant and weather-resistant membrane in flexible polyolefin (TPO/FPO) reinforced with dimensionally-stable glass mat, with a high-reflectance, Smart White surface (such as **Mapeplan T B 15** produced by POLYGLASS S.p.A.). The material must be produced by “multi-extrusion coating”, a single-step production process which allows the internal reinforcement to be inserted without pre-lamination, and must have a product certificate and marked with the CE symbol in compliance with EN 13956 standards.

The effective thickness must be at least 1.5 mm (-5/+10%) according to EN 1849-2 standards.

Fully-bond the turn-ups to the substrate using a specific contact adhesive (such as **Mapeplan ADS 300** produced by POLYGLASS S.p.A.).

Heat-weld the vertical turn-ups to the membrane using a manual and automatic hot-air welder after cleaning it with a specific cleaning product (such as Mapeplan T Cleaner produced by POLYGLASS S.p.A.).

Carry out manual heat-welding by spot-welding, internal pre-welding and final external welding to form a weathertight seal.

Included and calculated in the price for work carried out according to specification:

– per square metre

.....(€/m²)

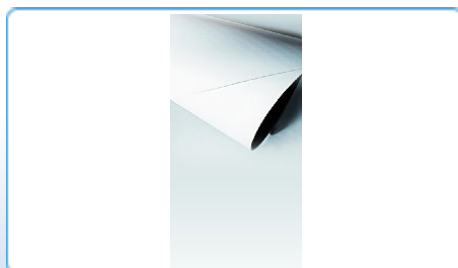

N.2 WATERPROOFING SYSTEMS FOR FLAT ROOFS BALLASTED WITH GRAVEL

N.2.1.9 Vertical turn-ups made from 1.8 mm-thick waterproof membrane in flexible polyolefin (TPO/FPO)

Supply and application of vertical turn-ups for waterproof membranes applied around the edges of roofs, wall fillets, mass fillets, skylights, etc., made from UV-resistant and weather-resistant membrane in flexible polyolefin (TPO/FPO) reinforced with dimensionally-stable glass mat, with a high-reflectance, Smart White surface (such as **Mapeplan T B** 18 produced by POLYGLASS S.p.A.). The material must be produced by “multi-extrusion coating”, a single-step production process which allows the internal reinforcement to be inserted without pre-lamination, and must have a product certificate and marked with the CE symbol in compliance with EN 13956 standards.

The effective thickness must be at least 1.8 mm (-5/+10%) according to EN 1849-2 standards.

Fully-bond the turn-ups to the substrate using a specific contact adhesive (such as **Mapeplan ADS 300** produced by POLYGLASS S.p.A.).

Heat-weld the vertical turn-ups to the membrane using a manual and automatic hot-air welder after cleaning it with a specific cleaning product (such as Mapeplan T Cleaner produced by POLYGLASS S.p.A.).

Carry out manual heat-welding by spot-welding, internal pre-welding and final external welding to form a weathertight seal.

Included and calculated in the price for work carried out according to specification:

– per square metre

.....(€/m²)

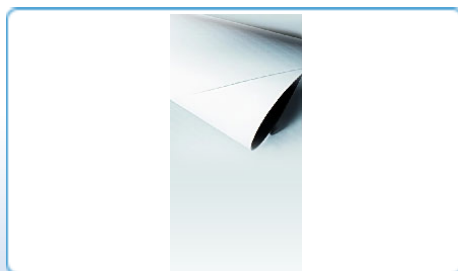

N.2 WATERPROOFING SYSTEMS FOR FLAT ROOFS BALLASTED WITH GRAVEL

N.2.1.10 Perimeter linear fixing system using pre-punched zinc-plated carbon steel profiled bars

Supply and application of an anti-peeling, linear, mechanical fixing system for the membrane applied around the perimeter of the roof, skylights, chimney stacks, wall fillets, etc. and fillets between horizontal and vertical surfaces.

The perimeter linear fixing system is applied around the membrane and comprises:

- Zinc-plated, carbon steel profiled fastening bars (such as Mapeplan Metalbar produced by POLYGLASS S.p.A.), with pre-punched 10x8 mm oval holes every 5 cm and the following dimensions: thickness 2 mm; width 33 mm; height 65 mm.
- The profiled bars must be mechanically strong and have a rounded profile compatible with the waterproof membrane.
- Fasteners suitable for the type of substrate (at least 4 fasteners per metre) (barring verification and approval by the manufacturer).
- 4 mm-diameter, anti-tear seaming cord applied around the zinc-plated carbon steel profiled bars by hot-air welding to the waterproof membrane.

The linear perimeter mechanical fixing system is applied to prevent loose-laid waterproof membranes from moving or being dragged due to variations in temperature, substrate deformation or deformations/movements of the insulation panels or underlying materials.

Included and calculated in the price for work carried out according to specification:

- per square metre(€/m)

N.2 WATERPROOFING SYSTEMS FOR FLAT ROOFS BALLASTED WITH GRAVEL

N.2.1.11 Application of non-woven fabric to form the protection layer

Supply and application of a protection layer made from 100% polypropylene non-woven, needle-punched fabric with a weight of 500 g/m² (such as **Polydren 500 PP** produced by POLYGLASS S.p.A.).

The product must have the following characteristics:

average tensile strength according to EN ISO 10319:	12 (-13%) kN/m
average elongation at maximum load according to EN ISO 10319:	> 50%
static puncture resistance CBR according to EN ISO 12236:	1.5 (-10%) kN
mass per unit area according to EN ISO 9864:	500 (-10%) g/m ²
flow capacity normal to the surface according to EN ISO 11058:	35 (-30%) l/m ² s

Loose-lay the product and overlap the edges of adjacent sheets by approximately 10 cm.

Included and calculated in the price for work carried out according to specification:

– per square metre(€/m²)



N.2 WATERPROOFING SYSTEMS FOR FLAT ROOFS BALLASTED WITH GRAVEL

N.2.1.12 Ballast layer

Supply and application of a layer of ballast to counteract the suction effect of wind, made from washed, round gravel with a grain size of 16 to 32 mm.

We recommend applying an even layer at least 50 mm thick. Apply the layer of ballast carefully to avoid damaging the underlying waterproofing layer.

Included and calculated in the price for work carried out according to specification:

– per square metre(€/m²)

N.2 WATERPROOFING SYSTEMS FOR FLAT ROOFS BALLASTED WITH GRAVEL

N.2.2 WATERPROOFING SYSTEMS FOR FLAT ROOFS BALLASTED WITH GRAVEL Procedure

Preparation of the substrate

Installation and/or checking of reinforced concrete or concrete-masonry substrates with a suitable cement levelling layer to form a slope (see section [N.1.1](#)).

When handed over, substrates must be smooth, clean and dry and all corners and edges must be smooth.

Application of the vapour barrier

After applying a coat of **Polyprimer HP 45** Professional specific primer, supply and application of a vapour barrier by bonding the entire self-adhesive surface of double-adhesive bituminous membrane such as **Polyvap SA** 2.0 mm (see section [N.2.2.1](#)), with overlaps approximately 10 cm wide between adjacent sheets. The membrane is made from a special SBS elastomeric compound with internal aluminium foil reinforcement, and the faces of the membrane are protected by a mono-silicon coated polyethylene film to be peeled when the membrane is applied.

Seal the overlaps between the sheets using a special metal roller.

Application of the insulating layer

Loose-laid rigid, self-extinguishing, dimensionally-stable insulating panels suitable for application on flat roofs, made from 200 kPa sintered expanded polystyrene (EPS) (see section [N.2.2.2](#)). Care must be taken when applying the panels to avoid forming thermal bridges.

Application of the separation layer

Loose-laid Polydren PES 200 thermo-calendered, 100% polyester non-woven, needle-punched fabric with a weight of 200 g/m², with overlaps approximately 10 cm wide between adjacent sheets (see section [N.2.2.3](#)). Note: not required with TPO/FPO membranes.

Application of the waterproof membrane

PVC-P membranes

Loose-laid **Mapeplan B 15** 1.5 mm-thick, UV-resistant and weather-resistant synthetic membrane in PVC-P, reinforced with dimensionally-stable glass mat, specifically formulated to resist microbiological attack and bacteria, laid with overlaps approximately 8 cm wide between adjacent sheets (see section [N.2.1.2](#)).

Or, loose-laid **Mapeplan B 18** 1.8 mm-thick, UV-resistant and weather-resistant synthetic membrane in PVC-P, reinforced with dimensionally-stable glass mat, specifically formulated to resist microbiological attack and bacteria, laid with overlaps approximately 8 cm wide between adjacent sheets (see section [N.2.1.3](#)).

Heat-weld the overlaps with a manual and automatic hot-air welder after cleaning them with Mapeplan Cleaner.

Carry out manual heat-welding by spot-welding, internal pre-welding and final external welding to form a weathertight seal.

Flexible polyolefin (TPO/FPO) membranes

Loose-laid **Mapeplan T B 15** 1.5 mm-thick, UV-resistant and weather-resistant synthetic waterproof membrane in flexible polyolefin (TPO/FPO) reinforced with dimensionally-stable glass mat, with a high-reflectance, Smart White surface, laid with overlaps approximately 8 cm wide between adjacent sheets (see section **N.2.1.4**).

Or, loose-laid **Mapeplan T B 18** 1.8 mm-thick, UV-resistant and weather-resistant synthetic waterproof membrane in flexible polyolefin (TPO/FPO) reinforced with dimensionally-stable glass mat, with a high-reflectance, Smart White surface, laid with overlaps approximately 8 cm wide between adjacent sheets (see section **N.2.1.5**).

Heat-weld the overlaps with a manual and automatic hot-air welder after cleaning them with Mapeplan T Cleaner.

Carry out manual heat-welding by spot-welding, internal pre-welding and final external welding to form a weathertight seal.

Vertical turn-ups**PVC-P membranes**

Vertical turn-ups for waterproof membranes around the edges of roofs, wall fillets, mass fillets, skylights, etc. using:

- **Mapeplan B 15** 1.5 mm-thick, UV-resistant and weather-resistant membrane in PVC-P reinforced with dimensionally-stable glass mat (see section **N.2.1.6**) for 1.5 mm thick waterproof membranes;
- **Mapeplan B 18** 1.8 mm-thick, UV-resistant and weather-resistant membrane in PVC-P reinforced with dimensionally-stable glass mat (see section **N.2.1.7**) for 1.8 mm thick waterproof membranes.

Fully-bond the turn-ups to the substrate using **Mapeplan ADS 200**, a specific contact adhesive.

Heat-weld the turn-ups to the membrane with a manual and/or automatic hot-air welder after cleaning them with Mapeplan Cleaner.

Carry out manual heat-welding by spot-welding, internal pre-welding and final external welding to form a weathertight seal.

Flexible Polyolefin (TPO/FPO) membranes

Vertical turn-ups for waterproof membranes around the edges of roofs, wall fillets, mass fillets, skylights, etc. using:

- **Mapeplan T B 15** 1.5 mm-thick, UV-resistant and weather-resistant membrane in flexible polyolefin (TPO/FPO) reinforced with dimensionally-stable glass mat, with a high-reflectance, Smart White surface (see section **N.2.1.8**) for 1.5 mm thick waterproof membranes;
- **Mapeplan T B 18** 1.8 mm-thick, UV-resistant and weather-resistant membrane in flexible Polyolefin (TPO/FPO) reinforced with dimensionally-stable glass mat, with a high-reflectance, Smart White surface (see section **N.2.1.9**) for 1.8 mm thick waterproof membranes.

Fully-bond the turn-ups to the substrate using **Mapeplan ADS 300**, a specific contact adhesive.

Heat-weld the turn-ups to the membrane with a manual and automatic hot-air welder after cleaning them with Mapeplan T Cleaner.

Carry out manual heat-welding by spot-welding, internal pre-welding and final external welding to form a weathertight seal.

Perimeter mechanical fixing system

A linear perimeter fixing system is applied to prevent loose-laid waterproof membranes from moving or being dragged due to variations in temperature, substrate deformation or deformations/movements of the insulating panels or underlying materials.

The fixing system (see section **N.2.1.10**) is applied around the perimeter of the roof, skylights, chimney stacks, wall fillets, etc. and fillets between horizontal and vertical surfaces, and comprises:

- Mapeplan Metalbar pre-punched, zinc-plated, carbon steel profiled fastening bars;
- Fasteners suitable for the type of substrate (at least 4 fasteners per metre);
- 4 mm-diameter, anti-tear seaming cord applied around the Mapeplan Metalbar profiles by hot-air welding to the Mapeplan waterproof membrane.

Application of the protection layer

Loose-laid **Polydren 500 PP** protection layer in 100% polypropylene non-woven, needle-punched fabric with a weight of 500 g/m², with overlaps approximately 10 cm wide between adjacent sheets (see section **N.2.1.11**).

Application of the ballast layer

Application of a layer of ballast to counteract the suction effect of wind, made from washed, round gravel with a grain size of 16 to 32 mm (see section **N.2.1.12**). Apply an even layer at least 50 mm thick. Apply the layer of ballast carefully to avoid damaging the underlying waterproofing layer.

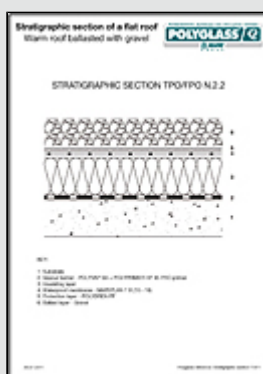
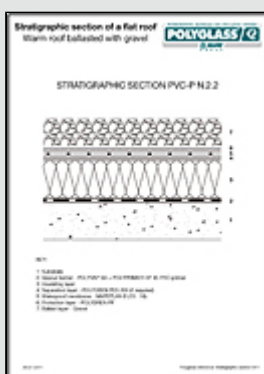

N.2 WATERPROOFING SYSTEMS FOR FLAT ROOFS BALLASTED WITH GRAVEL

N.2.2.1 Application of a vapour barrier using double-adhesive bituminous membrane

Supply and application of a vapour barrier using bituminous membrane (such as **Polyvap SA** 2.0 mm produced by POLYGLASS S.p.A.), made from special SBS elastomeric compound with internal aluminium foil, and faces protected by a mono-silicon coated polyethylene film to be peeled off when the membrane is applied, in compliance with EN 13970 product standards.

The membrane must have the following characteristics:

average nominal thickness according to EN 1849-2:	2.0 mm (\pm 0.2 mm)
resistance to the passage of vapour according to EN 1931:	μ ; factor 700,000 (\pm 30%)
flexibility at low temperatures according to EN 1109:	\leq -25 °C
maximum longitudinal tensile force according to EN 12311-1:	500 N/50 mm (-20%)
maximum transversal tensile force according to EN 12311-1:	200 N/50 mm (-20%).

Apply the barrier by fully-bonding the self-adhesive surface, with overlaps approximately 10 cm wide between adjacent sheets. Seal the overlaps using a special metal roller. Apply a coat of specific primer (such as **Polyprimer HP 45** Professional produced by POLYGLASS S.p.A.) before applying the vapour barrier.

Included and calculated in the price for work carried out according to specification:

– per square metre(€/m²)



N.2 WATERPROOFING SYSTEMS FOR FLAT ROOFS BALLASTED WITH GRAVEL

N.2.2.2 Application of an insulating layer using expanded polystyrene panels

Supply and application of rigid, self-extinguishing, dimensionally-stable insulation panels suitable for flat roofs, made from sintered expanded polystyrene (EPS 200 kPa). The panels must be made from non-recycled, virgin raw materials with CE certification in compliance with EN 13163 standards.

The product must have the following characteristics:

definition according to EN 13163:	EPS 200
thermal conductivity λ_d according to EN 13163:	0.034 W/mK
thickness:	XXX mm
compressive strength (10% deformation) according to EN 826:	200 kPa
fire resistance class according to EN 13501-1:	Euroclass E

Bond the panels in place and make sure they are perfectly butted together to prevent the formation of thermal bridges.

Included and calculated in the price for work carried out according to specification:

– *per square metre*(€/m²)

N.2 WATERPROOFING SYSTEMS FOR FLAT ROOFS BALLASTED WITH GRAVEL

N.2.2.3 Application of non-woven fabric to form the separation layer

Supply and application of a separation layer made from thermo-calendered, 100% polyester non-woven, needle-punched fabric with a weight of 200 g/m² (such as Polydren PES 200 produced by POLYGLASS S.p.A.).

The product must have the following characteristics:

longitudinal tensile strength according to EN ISO 10319: 3.4 kN/m

transversal tensile strength according to EN ISO 10319: 5.4 kN/m

longitudinal elongation at maximum load according to EN ISO 10319: 100%

transversal elongation at maximum load according to EN ISO 10319: 100%

static puncture resistance CBR according to EN ISO 12236: 0.8 kN

perforation resistance (cone drop test) according to EN ISO 13433: 26 mm

Loose-lay the product and overlap the edges of adjacent sheets by approximately 10 cm.

Included and calculated in the price for work carried out according to specification:

– per square metre(€/m²)

N.3 WATERPROOFING SYSTEMS FOR FLAT ROOFS BALLASTED WITH CEMENT SLABS ON SUPPORTS (SUITABLE FOR FOOT TRAFFIC)

N.3.1 WATERPROOFING SYSTEM FOR FLAT ROOFS BALLASTED WITH CEMENT SLABS ON SUPPORTS - COLD-ROOF SYSTEM Procedure

Preparation of the substrate

Installation and/or checking of reinforced concrete or concrete-masonry substrates with a suitable cement levelling layer to form a slope (see section [N.1.1](#)).

When handed over, substrates must be smooth, clean and dry and all corners and edges must be smooth.

Application of the compensation and levelling layer

Loose-laid **Polydren 500 PP** 100% polypropylene non-woven, needle-punched fabric with a weight of 500 g/m², with overlaps approximately 10 cm wide between adjacent sheets (see section [N.2.1.1](#)).

Application of the waterproof membrane

PVC-P membranes

- Loose-laid **Mapeplan B 15** 1.5 mm-thick, UV-resistant and weather-resistant synthetic membrane in PVC-P, reinforced with dimensionally-stable glass mat, specifically formulated to resist macrobiological attack and bacteria, laid with overlaps approximately 8 cm wide between adjacent sheets (see section [N.2.1.2](#)).
- Or, loose-laid **Mapeplan B 18** 1.8 mm-thick, UV-resistant and weather-resistant synthetic membrane in PVC-P, reinforced with dimensionally-stable glass mat, specifically formulated to resist macrobiological attack and bacteria, laid with overlaps approximately 8 cm wide between adjacent sheets (see section [N.2.1.3](#)).

Heat-weld the overlaps with a manual and automatic hot-air welder after cleaning them with Mapeplan Cleaner.

Carry out manual heat-welding by spot-welding, internal pre-welding and final external welding to form a weathertight seal.

Flexible Polyolefin (TPO/FPO) membranes

- Loose-laid **Mapeplan T B 15** 1.5 mm-thick, UV-resistant and weather-resistant synthetic waterproof membrane in flexible Polyolefin (TPO/FPO) reinforced with dimensionally-stable glass mat, with a high-reflectance, Smart White surface, laid with overlaps approximately 8 cm wide between adjacent sheets (see section [N.2.1.4](#)).
- Or, loose-laid **Mapeplan T B 18** 1.8 mm-thick, UV-resistant and weather-resistant synthetic waterproof membrane in flexible Polyolefin (TPO/FPO) reinforced with dimensionally-stable glass mat, with a high-reflectance, Smart White surface, laid with overlaps approximately 8 cm wide between adjacent sheets (see section [N.2.1.5](#)).

Heat-weld the overlaps with a manual and automatic hot-air welder after cleaning them with Mapeplan T Cleaner.

Carry out manual heat-welding by spot-welding, internal pre-welding and final external welding to form a weathertight seal.

Vertical turn-ups:**PVC-P membranes**

Vertical turn-ups for waterproof membranes around the edges of roofs, wall fillets, mass fillets, skylights, etc. using:

- **Mapeplan B 15** 1.5 mm-thick, UV-resistant and weather-resistant membrane in PVC-P reinforced with dimensionally-stable glass mat (see section **N.2.1.6**) for 1.5 mm thick waterproof membranes;
- **Mapeplan B 18** 1.8 mm-thick, UV-resistant and weather-resistant membrane in PVC-P reinforced with dimensionally-stable glass mat (see section **N.2.1.7**) for 1.8 mm thick waterproof membranes.

Fully-bond the turn-ups to the substrate using **Mapeplan ADS 200**, a specific contact adhesive.

Heat-weld the turn-ups to the membrane with a manual and/or automatic hot-air welder after cleaning them with Mapeplan Cleaner.

Carry out manual heat-welding by spot-welding, internal pre-welding and final external welding to form a weathertight seal.

Flexible Polyolefin (TPO/FPO) membranes

Vertical turn-ups for waterproof membranes around the edges of roofs, wall fillets, mass fillets, skylights, etc. using:

- **Mapeplan T B 15** 1.5 mm-thick, UV-resistant and weather-resistant membrane in flexible polyolefin (TPO/FPO) reinforced with dimensionally-stable glass mat with a high-reflectance, Smart White surface (see section **N.2.1.8**) for 1.5 mm thick waterproof membranes;
- **Mapeplan T B 18** 1.8 mm-thick, UV-resistant and weather-resistant membrane in flexible Polyolefin (TPO/FPO) reinforced with dimensionally-stable glass mat with a high-reflectance, Smart White surface (see section **N.2.1.9**) for 1.8 mm thick waterproof membranes.

Fully-bond the turn-ups to the substrate using **Mapeplan ADS 300**, a specific contact adhesive.

Heat-weld the turn-ups to the membrane with a manual and automatic hot-air welder after cleaning them with Mapeplan T Cleaner.

Carry out manual heat-welding by spot-welding, internal pre-welding and final external welding to form a weathertight seal.

Perimeter mechanical fixing system

A linear perimeter fixing system is applied to prevent loose-laid waterproof membranes from moving or being dragged due to variations in temperature, substrate deformation or deformations/movements of the insulating panels or underlying materials.

The fixings system (see section **N.2.1.10**) is applied around the perimeter of the roof, skylights, chimney stacks, wall fillets, etc. and fillets between horizontal and vertical surfaces, and comprises:

- Mapeplan Metalbar pre-punched, zinc-plated, carbon steel profiled fastening bars;
- Fasteners suitable for the type of substrate (at least 4 fasteners per metre);
- 4 mm-diameter, anti-tear seaming cord applied around the Mapeplan Metalbar profiles by hot-air welding to the Mapeplan waterproof membrane.

Application of the protection layer

Loose-laid **Polydren 500 PP** protection layer in 100% polypropylene non-woven, needle-punched fabric with a weight of 500 g/m², with overlaps approximately 10 cm wide between adjacent sheets (see section **N.2.1.11**).

Application of the ballast layer

Supply and application of a layer of ballast to counteract the suction effect of wind, made from cement slabs with a washed-gravel surface, reinforced internally with round metal bars (see section **N.3.1.1**). The size of the slab must be 40×50 cm or 50×50 cm.

Loose-lay the slabs on plastic supports with a separation layer between, if necessary.

Apply the layer of ballast carefully to avoid damaging the underlying waterproofing layer.



N.3 WATERPROOFING SYSTEMS FOR FLAT ROOFS BALLASTED WITH CEMENT SLABS ON SUPPORTS (SUITABLE FOR FOOT TRAFFIC)

N.3.1.1 Application of a ballast layer made from cement slabs on supports

Supply and application of a layer of ballast to counteract the suction effect of wind, made from cement slabs with a washed-gravel surface, reinforced internally with round metal bars.

The size of the slabs must be 40×50 cm or 50×50 cm.

Loose-lay the slabs on plastic supports with a separation layer between, if necessary. Apply the layer of ballast carefully to avoid damaging the underlying waterproofing layer.

Included and calculated in the price for work carried out according to specification:

– per square metre

.....(€/m²)

N.3 WATERPROOFING SYSTEMS FOR FLAT ROOFS BALLASTED WITH CEMENT SLABS ON SUPPORTS (SUITABLE FOR FOOT TRAFFIC)

N.3.2 WATERPROOFING SYSTEMS FOR FLAT ROOFS BALLASTED WITH CEMENT SLABS ON SUPPORTS - WARM-ROOF SYSTEM Procedure

Preparation of the substrate

Installation and/or checking of reinforced concrete or concrete-masonry substrates with a suitable cement levelling layer to form a slope (see section [N.1.1](#)).

When handed over, substrates must be smooth, clean and dry and all corners and edges must be smooth.

Application of the vapour barrier

After applying a coat of **Polyprimer HP 45** Professional specific primer, supply and application of a vapour barrier by bonding the entire self-adhesive surface of double-adhesive bituminous membrane such as **Polyvap SA** 2.0 mm (see section [N.2.2.1](#)), with overlaps approximately 10 cm wide between adjacent sheets. The membrane is made from a special SBS elastomeric compound with internal aluminium foil reinforcement, and the faces of the membrane are protected by a mono-silicon coated polyethylene film to be peeled when the membrane is applied.

Seal the overlaps between the sheets using a special metal roller.

Application of the insulating layer

Loose-laid rigid, self-extinguishing, dimensionally-stable insulating panels made from 200 kPa sintered, expanded polystyrene (EPS) (see section [N.2.2.2](#)) suitable for application on flat roofs, slotted together on all four sides and laid carefully to avoid the formation of thermal bridges.

Application of the separation layer

Loose-laid Polydren PES 200 thermo-calendered, 100% polyester non-woven, needle-punched fabric with a weight of 200 g/m², with overlaps approximately 10 cm wide between adjacent sheets (see section [N.2.2.3](#)). Note: not required with TPO/FPO membranes.

Application of the waterproof membrane

PVC-P membranes

- Loose-laid **Mapeplan B 15** 1.5 mm-thick, UV-resistant and weather-resistant synthetic membrane in PVC-P, reinforced with dimensionally-stable glass mat, specifically formulated to resist macrobiological attack and bacteria, laid with overlaps approximately 8 cm wide between adjacent sheets (see section [N.2.1.2](#)).
- Or, loose-laid **Mapeplan B 18** 1.8 mm-thick, UV-resistant and weather-resistant synthetic membrane in PVC-P, reinforced with dimensionally-stable glass mat, specifically formulated to resist macrobiological attack and bacteria, laid with overlaps approximately 8 cm wide between adjacent sheets (see section [N.2.1.3](#)).

Heat-weld the overlaps with a manual and automatic hot-air welder after cleaning them with Mapeplan Cleaner.

Carry out manual heat-welding by spot-welding, internal pre-welding and final external welding to form a weathertight seal.

Flexible Polyolefin (TPO/FPO) membranes

- Loose-laid **Mapeplan T B 15** 1.5 mm-thick, UV-resistant and weather-resistant synthetic waterproof membrane in flexible Polyolefin (TPO/FPO) reinforced with dimensionally-stable glass mat, with a high-reflectance, Smart White surface, laid with overlaps approximately 8 cm wide between adjacent sheets (see section **N.2.1.4**).
- Or, loose-laid **Mapeplan T B 18** 1.8 mm-thick, UV-resistant and weather-resistant synthetic waterproof membrane in flexible Polyolefin (TPO/FPO) reinforced with dimensionally-stable glass mat, with a high-reflectance, Smart White surface, laid with overlaps approximately 8 cm wide between adjacent sheets (see section **N.2.1.5**).

Heat-weld the overlaps with a manual and automatic hot-air welder after cleaning them with Mapeplan T Cleaner.

Carry out manual heat-welding by spot-welding, internal pre-welding and final external welding to form a weathertight seal.

Vertical turn-ups

PVC-P membranes

Vertical turn-ups for waterproof membranes around the edges of roofs, wall fillets, mass fillets, skylights, etc. using:

- **Mapeplan B 15** 1.5 mm-thick, UV-resistant and weather-resistant membrane in PVC-P reinforced with dimensionally-stable glass mat (see section **N.2.1.6**) for 1.5 mm thick waterproof membranes;
- **Mapeplan B 18** 1.8 mm-thick, UV-resistant and weather-resistant membrane in PVC-P reinforced with dimensionally-stable glass mat (see section **N.2.1.7**) for 1.8 mm thick waterproof membranes.

Fully-bond the turn-ups to the substrate using **Mapeplan ADS 200**, a specific contact adhesive.

Heat-weld the turn-ups to the membrane with a manual and/or automatic hot-air welder after cleaning them with Mapeplan Cleaner.

Carry out manual heat-welding by spot-welding, internal pre-welding and final external welding to form a weathertight seal.

Flexible Polyolefin (TPO/FPO) membranes

Vertical turn-ups for waterproof membranes around the edges of roofs, wall fillets, mass fillets, skylights, etc. using:

- **Mapeplan T B 15** 1.5 mm-thick, UV-resistant and weather-resistant membrane in flexible polyolefin (TPO/FPO) reinforced with dimensionally-stable glass mat with a high-reflectance, Smart White surface (see section **N.2.1.8**) for 1.5 mm thick waterproof membranes;
- **Mapeplan T B 18** 1.8 mm-thick, UV-resistant and weather-resistant membrane in flexible Polyolefin (TPO/FPO) reinforced with dimensionally-stable glass mat with a high-reflectance, Smart White surface (see section **N.2.1.9**) for 1.8 mm thick waterproof membranes.

Fully-bond the turn-ups to the substrate using **Mapeplan ADS 300**, a specific contact adhesive.

Heat-weld the turn-ups to the membrane with a manual and automatic hot-air welder after cleaning them with Mapeplan T Cleaner.

Carry out manual heat-welding by spot-welding, internal pre-welding and final external welding to form a weathertight seal.

Perimeter mechanical fixing system

A linear perimeter fixing system is applied to prevent loose-laid waterproof membranes from moving or being dragged due to variations in temperature, substrate deformation or deformations/movements of the insulating panels or underlying materials.

The fixing system (see section **N.2.1.10**) is applied around the perimeter of the roof, skylights, chimney stacks, wall fillets, etc. and fillets between horizontal and vertical surfaces, and comprises:

- Mapeplan Metalbar pre-punched, zinc-plated, carbon steel profiled fastening bars;
- Fasteners suitable for the type of substrate (at least 4 fasteners per metre);
- 4 mm-diameter, anti-tear seaming cord applied around the Mapeplan Metalbar profiles by hot-air welding to the Mapeplan waterproof membrane.

Application of the protection layer

Loose-laid **Polydren 500 PP** protection layer in 100% polypropylene non-woven, needle-punched fabric with a weight of 500 g/m², with overlaps approximately 10 cm wide between adjacent sheets (see section **N.2.1.11**).

Application of the ballast layer

Supply and application of a layer of ballast to counteract the suction effect of wind, made from cement slabs with a washed-gravel surface, reinforced internally with round metal bars (see section **N.3.1.1**). The size of the slab must be 40×50 cm or 50×50 cm.

Loose-lay the slabs on plastic supports with a separation layer between, if necessary.

Apply the layer of ballast carefully to avoid damaging the underlying waterproofing layer.



N.4 WATERPROOFING SYSTEMS FOR FLAT ROOFS BALLASTED WITH BONDED TILES (SUITABLE FOR FOOT TRAFFIC)

N.4.1 WATERPROOFING SYSTEMS FOR FLAT ROOFS BALLASTED WITH BONDED TILES - COLD-ROOF SYSTEM **Procedure**

Preparation of the substrate

Installation and/or checking of reinforced concrete or concrete-masonry substrates with a suitable cement levelling layer to form a slope (see section [N.1.1](#)).

When handed over, substrates must be smooth, clean and dry and all corners and edges must be smooth.

Application of the compensation and levelling layer

Loose-laid Polydren 500 PP 100% polypropylene non-woven, needle-punched fabric with a weight of 500 g/m², with overlaps approximately 10 cm wide between adjacent sheets (see section [N.2.1.1](#)).

Application of the waterproof membrane

PVC-P membranes

- Loose-laid **Mapeplan B 15** 1.5 mm-thick, UV-resistant and weather-resistant synthetic membrane in PVC-P, reinforced with dimensionally-stable glass mat, specifically formulated to resist macrobiological attack and bacteria, laid with overlaps approximately 8 cm wide between adjacent sheets (see section [N.2.1.2](#)).
- Or, loose-laid **Mapeplan B 18** 1.8 mm-thick, UV-resistant and weather-resistant synthetic membrane in PVC-P, reinforced with dimensionally-stable glass mat, specifically formulated to resist macrobiological attack and bacteria, laid with overlaps approximately 8 cm wide between adjacent sheets (see section [N.2.1.3](#)).

Heat-weld the overlaps with a manual and automatic hot-air welder after cleaning them with Mapeplan Cleaner.

Carry out manual heat-welding by spot-welding, internal pre-welding and final external welding to form a weathertight seal.

Flexible Polyolefin (TPO/FPO) membranes

- Loose-laid **Mapeplan T B 15** 1.5 mm-thick, UV-resistant and weather-resistant synthetic waterproof membrane in flexible Polyolefin (TPO/FPO) reinforced with dimensionally-stable glass mat, with a high-reflectance, Smart White surface, laid with overlaps approximately 8 cm wide between adjacent sheets (see section [N.2.1.4](#)).
- Or, loose-laid **Mapeplan T B 18** 1.8 mm-thick, UV-resistant and weather-resistant synthetic waterproof membrane in flexible Polyolefin (TPO/FPO) reinforced with dimensionally-stable glass mat, with a high-reflectance, Smart White surface, laid with overlaps approximately 8 cm wide between adjacent sheets (see section [N.2.1.5](#)).

Heat-weld the overlaps with a manual and automatic hot-air welder after cleaning them with Mapeplan T Cleaner.

Carry out manual heat-welding by spot-welding, internal pre-welding and final external welding to form a weathertight seal.

Vertical turn-ups**PVC-P membranes**

Vertical turn-ups for waterproof membranes around the edges of roofs, wall fillets, mass fillets, skylights, etc. using:

- **Mapeplan B 15** 1.5 mm-thick, UV-resistant and weather-resistant membrane in PVC-P reinforced with dimensionally-stable glass mat (see section **N.2.1.6**) for 1.5 mm thick waterproof membranes.
- **Mapeplan B 18** 1.8 mm-thick, UV-resistant and weather-resistant membrane in PVC-P reinforced with dimensionally-stable glass mat (see section **N.2.1.7**) for 1.8 mm thick waterproof membranes.

Fully-bond the turn-ups to the substrate using **Mapeplan ADS 200**, a specific contact adhesive.

Heat-weld the turn-ups to the membrane with a manual and/or automatic hot-air welder after cleaning them with Mapeplan Cleaner.

Carry out manual heat-welding by spot-welding, internal pre-welding and final external welding to form a weathertight seal.

Flexible Polyolefin (TPO/FPO) membranes

Vertical turn-ups for waterproof membranes around the edges of roofs, wall fillets, mass fillets, skylights, etc. using:

- **Mapeplan T B 15** 1.5 mm-thick, UV-resistant and weather-resistant membrane in flexible polyolefin (TPO/FPO) reinforced with dimensionally-stable glass mat with a high-reflectance, Smart White surface (see section **N.2.1.8**) for 1.5 mm thick waterproof membranes.
- **Mapeplan T B 18** 1.8 mm-thick, UV-resistant and weather-resistant membrane in flexible Polyolefin (TPO/FPO) reinforced with dimensionally-stable glass mat with a high-reflectance, Smart White surface (see section **N.2.1.9**) for 1.8 mm thick waterproof membranes.

Fully-bond the turn-ups to the substrate using **Mapeplan ADS 300**, a specific contact adhesive.

Heat-weld the turn-ups to the membrane with a manual and automatic hot-air welder after cleaning them with Mapeplan T Cleaner.

Carry out manual heat-welding by spot-welding, internal pre-welding and final external welding to form a weathertight seal.

Perimeter mechanical fixing system

A linear perimeter fixing system is applied to prevent loose-laid waterproof membranes from moving or being dragged due to variations in temperature, substrate deformation or deformations/movements of the insulating panels or underlying materials.

The fixings system (see section **N.2.1.10**) is applied around the perimeter of the roof, skylights, chimney stacks, wall fillets, etc. and fillets between horizontal and vertical surfaces, and comprises:

- Mapeplan Metalbar pre-punched, zinc-plated, carbon steel profiled fastening bars;
- Fasteners suitable for the type of substrate (at least 4 fasteners per metre);
- 4 mm-diameter, anti-tear seaming cord applied around the Mapeplan Metalbar profiles by hot-air welding to the Mapeplan waterproof membrane.

Application of the protection layer

Loose-laid Polydren 500 PP protection layer in 100% polypropylene non-woven, needle-punched fabric with a weight of 500 g/m², with overlaps approximately 10 cm wide between adjacent sheets (see section [N.2.1.11](#)).

Application of the anti-imbibition flow layer

Loose-laid anti-imbibition flow layer to prevent cement laitance clogging/modifying the underlying layer, made from 0.1 mm-thick, micro-perforated, low-density LDPE polyethylene sheet (such as Mapeplan LDPE Microforato 0.10 mm produced by POLYGLASS S.p.A.)(see section [N.4.2.2](#)).

Seal the overlaps using single-sided adhesive tape.

Application of the ballast layer

Frost-proof tiled flooring suitable for foot traffic (see section [N.4.1.1](#)), applied by bonding the tiles with a specific adhesive on a suitably-prepared cementitious substrate and with expansion joints in the flooring.

Apply a continuous cushioning layer of sheets of foam material around the perimeter of the flooring, to prevent thermal expansion of the flooring pushing against the edges and damaging the vertical turn-ups.

Apply the flooring carefully to avoid damaging the underlying waterproofing layer.

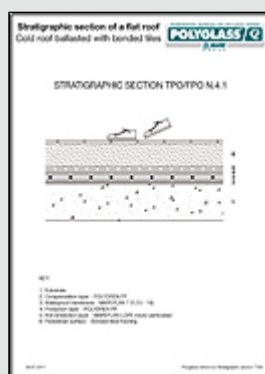

N.4 WATERPROOFING SYSTEMS FOR FLAT ROOFS BALLASTED WITH BONDED TILES (SUITABLE FOR FOOT TRAFFIC)

N.4.1.1 Application of a ballast layer made from tiled flooring suitable for foot traffic

Supply and application of frost-proof, tiled flooring suitable for foot traffic pedestrian use according to design specifications, applied by bonding the tiles with a specific adhesive on a suitably-prepared cementitious substrate and with expansion joints in the flooring.

Apply a continuous cushioning layer of sheets of foam material around the perimeter of the flooring, to prevent thermal expansion of the flooring pushing against the edges and damaging the vertical turn-ups.

Apply the flooring carefully to avoid damaging the underlying waterproofing layer.

Included and calculated in the price for work carried out according to specification:

– per square metre

.....(€/m²)

N.4 WATERPROOFING SYSTEMS FOR FLAT ROOFS BALLASTED WITH BONDED TILES (SUITABLE FOR FOOT TRAFFIC)

N.4.2 WATERPROOFING SYSTEMS FOR FLAT ROOFS BALLASTED WITH BONDED TILES - WARM-ROOF SYSTEM Procedure

Preparation of the substrate

Installation and/or checking of reinforced concrete or concrete-masonry substrates with a suitable cement levelling layer to form a slope (see section [N.1.1](#)).

When handed over, substrates must be smooth, clean and dry and all corners and edges must be smooth.

Application of the vapour barrier

After applying a coat of **Polyprimer HP 45** Professional specific primer, supply and application of a vapour barrier by bonding the entire self-adhesive surface of double-adhesive bituminous membrane such as **Polyvap SA** 2.0 mm (see section [N.2.2.1](#)), with overlaps approximately 10 cm wide between adjacent sheets. The membrane is made from a special SBS elastomeric compound with internal aluminium foil reinforcement, and the faces of the membrane are protected by a mono-silicon coated polyethylene film to be peeled off when the membrane is applied.

Seal the overlaps between the sheets using a special metal roller.

Application of the insulating layer

Loose-laid rigid, self-extinguishing, dimensionally-stable insulating panels suitable for application on flat roofs, made from 200 kPa sintered expanded polystyrene (EPS) (see section [N.2.2.2](#)). Care must be taken when applying the panels to avoid forming thermal bridges.

Application of the separation layer

Loose-laid Polydren PES 200 thermo-calendered, 100% polyester non-woven, needle-punched fabric with a weight of 200 g/m², with overlaps approximately 10 cm wide between adjacent sheets (see section [N.2.2.3](#)). Note: not required with TPO/FPO membranes.

Application of the waterproof membrane

PVC-P membranes

- Loose-laid **Mapeplan B 15** 1.5 mm-thick, UV-resistant and weather-resistant synthetic membrane in PVC-P, reinforced with dimensionally-stable glass mat, specifically formulated to resist macrobiological attack and bacteria, laid with overlaps approximately 8 cm wide between adjacent sheets (see section [N.2.1.2](#)).
- Or, loose-laid **Mapeplan B 18** 1.8 mm-thick, UV-resistant and weather-resistant synthetic membrane in PVC-P, reinforced with dimensionally-stable glass mat, specifically formulated to resist macrobiological attack and bacteria, laid with overlaps approximately 8 cm wide between adjacent sheets (see section [N.2.1.3](#)).

Heat-weld the overlaps with a manual and automatic hot-air welder after cleaning them with Mapeplan Cleaner.

Carry out manual heat-welding by spot-welding, internal pre-welding and final external welding to form a weathertight seal.

Flexible Polyolefin (TPO/FPO) membranes

- Loose-laid **Mapeplan T B 15** 1.5 mm-thick, UV-resistant and weather-resistant synthetic waterproof membrane in flexible Polyolefin (TPO/FPO) reinforced with dimensionally-stable glass mat, with a high-reflectance, Smart White surface, laid with overlaps approximately 8 cm wide between adjacent sheets (see section **N.2.1.4**).
- Or, loose-laid **Mapeplan T B 18** 1.8 mm-thick, UV-resistant and weather-resistant synthetic waterproof membrane in flexible Polyolefin (TPO/FPO) reinforced with dimensionally-stable glass mat, with a high-reflectance, Smart White surface, laid with overlaps approximately 8 cm wide between adjacent sheets (see section **N.2.1.5**).

Heat-weld the overlaps with a manual and automatic hot-air welder after cleaning them with Mapeplan T Cleaner.

Carry out manual heat-welding by spot-welding, internal pre-welding and final external welding to form a weathertight seal.

Vertical turn-ups

PVC-P membranes

Vertical turn-ups for waterproof membranes around the edges of roofs, wall fillets, mass fillets, skylights, etc. using:

- **Mapeplan B 15** 1.5 mm-thick, UV-resistant and weather-resistant membrane in PVC-P reinforced with dimensionally-stable glass mat (see section **N.2.1.6**) for 1.5 mm thick waterproof membranes;
- **Mapeplan B 18** 1.8 mm-thick, UV-resistant and weather-resistant membrane in PVC-P reinforced with dimensionally-stable glass mat (see section **N.2.1.7**) for 1.8 mm thick waterproof membranes.

Fully-bond the turn-ups to the substrate using **Mapeplan ADS 200**, a specific contact adhesive.

Heat-weld the turn-ups to the membrane with a manual and/or automatic hot-air welder after cleaning them with Mapeplan Cleaner.

Carry out manual heat-welding by spot-welding, internal pre-welding and final external welding to form a weathertight seal.

Flexible Polyolefin (TPO/FPO) membranes

Vertical turn-ups for waterproof membranes around the edges of roofs, wall fillets, mass fillets, skylights, etc. using:

- **Mapeplan T B 15** 1.5 mm-thick, UV-resistant and weather-resistant membrane in flexible polyolefin (TPO/FPO) reinforced with dimensionally-stable glass mat with a high-reflectance, Smart White surface (see section **N.2.1.8**) for 1.5 mm thick waterproof membranes;
- **Mapeplan T B 18** 1.8 mm-thick, UV-resistant and weather-resistant membrane in flexible Polyolefin (TPO/FPO) reinforced with dimensionally-stable glass mat with a high-reflectance, Smart White surface (see section **N.2.1.9**) for 1.8 mm thick waterproof membranes.

Fully-bond the turn-ups to the substrate using **Mapeplan ADS 300**, a specific contact adhesive.

Heat-weld the turn-ups to the membrane with a manual and automatic hot-air welder after cleaning them with Mapeplan T Cleaner.

Carry out manual heat-welding by spot-welding, internal pre-welding and final external welding to form a weathertight seal.

Perimeter mechanical fixing system

A perimeter fixing system is applied to prevent loose-laid waterproof membranes from moving or being dragged due to variations in temperature, substrate deformation or deformations/movements of the insulating panels, and before applying rigid, heavy layers of ballast (see section [N.4.2.1](#)).

The anti-peeling, linear mechanical fixing system is applied around the perimeter of the roof, skylights, chimney stacks, wall fillets, etc. and fillets between horizontal and vertical surfaces, and comprises:

- Aluzinc-plated, carbon steel anchoring plates suitable for use with waterproof membranes. The plates are treated with a suitable anti-corrosion product and measure 82x40x1 mm;
- fasteners suitable for the type of substrate (at least 4 fasteners per metre).

Application of the protection layer

Loose-laid Polydren 500 PP protection layer in 100% polypropylene non-woven, needle-punched fabric with a weight of 500 g/m², with overlaps approximately 10 cm wide between adjacent sheets (see section [N.2.1.11](#)).

Application of the anti-imbibition flow layer

Loose-laid anti-imbibition flow layer to prevent cement laitance clogging/modifying the underlying layer, made from 0.1 mm-thick, micro-perforated, low-density LDPE polyethylene sheet (such as Mapeplan LDPE Microforato 0.10 mm produced by POLYGLASS S.p.A.), laid with overlaps approximately 10 cm wide between adjacent sheets (see section [N.4.2.2](#)).

Seal the overlaps using single-sided adhesive tape.

Application of the ballast layer

Frost-proof tiled flooring suitable for foot traffic (see section [N.4.1.1](#)), applied by bonding the tiles with a specific adhesive on a suitably-prepared cementitious substrate with expansion joints in the flooring.

Apply a continuous cushioning layer of sheets of foam material around the perimeter of the flooring, to prevent thermal expansion of the flooring pushing against the edges and damaging the vertical turn-ups.

Apply the flooring carefully to avoid damaging the underlying waterproofing layer.

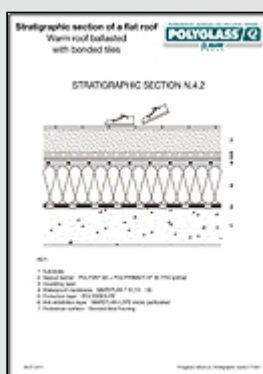
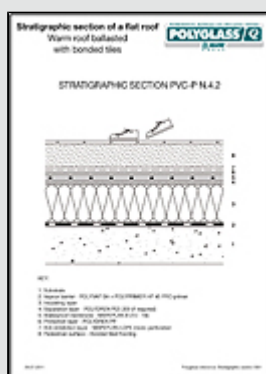

N.4 WATERPROOFING SYSTEMS FOR FLAT ROOFS BALLASTED WITH BONDED TILES (SUITABLE FOR FOOT TRAFFIC)

N.4.2.1 Perimeter mechanical fixing system using steel plates and fasteners

Anti-peeling, linear, mechanical fixing system for the membrane (such as Mapeplan produced by POLYGLASS S.p.A.), applied around the perimeter of the roof, skylights, chimney stacks, wall fillets, etc. and fillets between horizontal and vertical surfaces.

The fixing system is applied before the rigid, heavy layer of ballast, and comprises:

- Aluzinc-plated, carbon steel anchoring plates suitable for use with waterproof membranes. The plates are treated with a suitable anti-corrosion product and measure 82x40x1 mm.
- Fasteners suitable for the type of substrate (at least 4 fasteners per metre).

Included and calculated in the price for work carried out according to specification:

- *per square metre*(€/m)

N.4 WATERPROOFING SYSTEMS FOR FLAT ROOFS BALLASTED WITH BONDED TILES (SUITABLE FOR FOOT TRAFFIC)

N.4.2.2 Application of an anti-imbibition flow layer using low-density, micro-perforated polyethylene

Supply and application of an anti-imbibition flow layer to prevent cement laitance clogging/modifying the underlying layer, made from 0.1 mm-thick, micro-perforated, low-density LDPE polyethylene sheet (such as Mapeplan LDPE Microforato 0.10 mm produced by POLYGLASS S.p.A.).

The material must have the following characteristics:

nominal thickness:	0.10 mm
pitch of cold-formed micro-perforations:	30×30 mm
vapour diffusion resistance factor μ :	54,000 (\pm 5000) according to EN 1931
elongation at failure:	\geq 300%
resistance to the passage of vapour S_D :	5.4 m

Loose-lay the material and overlap the edges of adjacent sheets by approximately 10 cm. Seal the overlaps using single-sided adhesive tape.

Included and calculated in the price for work carried out according to specification:

– per square metre(€/m²)

N.5 WATERPROOFING SYSTEMS FOR FLAT ROOFS BALLASTED WITH A CONCRETE SCREED (SUITABLE FOR FOOT/VEHICULAR TRAFFIC)

N.5.1 WATERPROOFING SYSTEMS FOR FLAT ROOFS BALLASTED WITH A CONCRETE SCREED - COLD-ROOF SYSTEM

Procedure

Preparation of the substrate

Installation and/or checking of reinforced concrete or concrete-masonry substrates with a suitable cement levelling layer to form a slope (see section [N.1.1](#)).

When handed over, substrates must be smooth, clean and dry and all corners and edges must be smooth.

Application of the compensation and levelling layer

Loose-laid Polydren 500 PP 100% polypropylene non-woven, needle-punched fabric with a weight of 500 g/m², with overlaps approximately 10 cm wide between adjacent sheets (see section [N.2.1.1](#)).

Application of the waterproof membrane

PVC-P membranes

- Loose-laid **Mapeplan B 15** (FOR LIGHT VEHICLES: < 2 tonnes/axis) 1.5 mm-thick, UV-resistant and weather-resistant synthetic membrane in PVC-P, reinforced with dimensionally-stable glass mat, specifically formulated to resist macrobiological attack and bacteria, laid with overlaps approximately 8 cm wide between adjacent sheets (see section [N.2.1.2](#)).
- Or, loose-laid **Mapeplan B 20** (FOR HEAVY VEHICLES: ≥ 2 tonnes/axis) 2.0 mm-thick, UV-resistant and weather-resistant synthetic membrane in PVC-P, reinforced with dimensionally-stable glass mat, specifically formulated to resist macrobiological attack and bacteria, laid with overlaps approximately 8 cm wide between adjacent sheets (see section [N.5.1.1](#)).

Heat-weld the overlaps with a manual and automatic hot-air welder after cleaning them with Mapeplan Cleaner.

Carry out manual heat-welding by spot-welding, internal pre-welding and final external welding to form a weathertight seal.

Flexible Polyolefin (TPO/FPO) membranes

- Loose-laid **Mapeplan T B 15** (FOR LIGHT VEHICLES: < 2 tonnes/axis) 1.5 mm-thick, UV-resistant and weather-resistant synthetic waterproof membrane in flexible Polyolefin (TPO/FPO) reinforced with dimensionally-stable glass mat, with a high-reflectance, Smart White surface, laid with overlaps approximately 8 cm wide between adjacent sheets (see section [N.2.1.4](#)).
- Or, loose-laid **Mapeplan T B 20** (FOR HEAVY VEHICLES: ≥ 2 tonnes/axis) 2.0 mm-thick, UV-resistant and weather-resistant synthetic waterproof membrane in flexible polyolefin (TPO/FPO) reinforced with dimensionally-stable glass mat, with a high-reflectance, Smart White surface, laid with overlaps approximately 8 cm wide between adjacent sheets (see section [N.5.1.2](#)).

Heat-weld the overlaps with a manual and automatic hot-air welder after cleaning them with Mapeplan T Cleaner.

Carry out manual heat-welding by spot-welding, internal pre-welding and final external welding to form a weathertight seal.

Vertical turn-ups**PVC-P membranes**

Vertical turn-ups for waterproof membranes around the edges of roofs, wall fillets, mass fillets, skylights, etc. using:

- **Mapeplan B 15** 1.5 mm-thick, UV-resistant and weather-resistant membrane in PVC-P reinforced with dimensionally-stable glass mat (see section **N.2.1.6**) for 1.5 mm thick waterproof membranes;
- **Mapeplan B 20** 2.0 mm-thick, UV-resistant and weather-resistant membrane in PVC-P reinforced with dimensionally-stable glass mat (see section **N.5.1.3**) for 2.0 mm thick waterproof membranes.

Fully-bond the turn-ups to the substrate using **Mapeplan ADS 200**, a specific contact adhesive.

Heat-weld the turn-ups to the membrane with a manual and/or automatic hot-air welder after cleaning them with Mapeplan Cleaner.

Carry out manual heat-welding by spot-welding, internal pre-welding and final external welding to form a weathertight seal.

Flexible Polyolefin (TPO/FPO) membranes

Vertical turn-ups for waterproof membranes around the edges of roofs, wall fillets, mass fillets, skylights, etc. using:

- **Mapeplan T B 15** 1.5 mm-thick, UV-resistant and weather-resistant membrane in flexible polyolefin (TPO/FPO) reinforced with dimensionally-stable glass mat with a high-reflectance, Smart White surface (see section **N.2.1.8**) for 1.5 mm thick waterproof membranes;
- **Mapeplan T B 20** 2.0 mm-thick, UV-resistant and weather-resistant membrane in flexible polyolefin (TPO/FPO) reinforced with dimensionally-stable glass mat with a high-reflectance, Smart White surface (see section **N.5.1.4**) for 2.0 mm thick waterproof membranes.
- Fully-bond the turn-ups to the substrate using **Mapeplan ADS 300**, a specific contact adhesive.

Heat-weld the turn-ups to the membrane with a manual and automatic hot-air welder after cleaning them with Mapeplan T Cleaner.

Carry out manual heat-welding by spot-welding, internal pre-welding and final external welding to form a weathertight seal.

Perimeter mechanical fixing system

A perimeter fixing system is applied to prevent loose-laid waterproof membranes from moving or being dragged due to variations in temperature, substrate deformation or deformations/movements of the insulating panels, and before applying rigid, heavy layers of ballast (see section **N.4.2.1**).

The anti-peeling, linear mechanical fixing system is applied around the perimeter of the roof, skylights, chimney stacks, wall fillets, etc. and fillets between horizontal and vertical surfaces, and comprises:

- Aluzinc-plated, carbon steel anchoring plates suitable for use with waterproof membranes. The plates are treated with a suitable anti-corrosion product and measure 82×40×1 mm;
- Fasteners suitable for the type of substrate (at least 4 fasteners per metre).

Application of the protection layer

Loose-laid Polydren 500 PP protection layer in 100% polypropylene non-woven, needle-punched fabric with a weight of 500 g/m², with overlaps approximately 10 cm wide between adjacent sheets (see section [N.2.1.11](#)).

Application of the anti-imbibition flow layer

Loose-laid anti-imbibition flow layer to prevent cement laitance clogging/modifying the underlying layer, made from 0.1 mm-thick, micro-perforated, low-density LDPE polyethylene sheet (such as Mapeplan LDPE Microforato 0.10 mm produced by MAPEI S.p.A.), laid with overlaps approximately 10 cm wide between adjacent sheets (see section [N.4.2.2](#)).

Seal the overlaps using single-sided adhesive tape.

Application of the ballast layer

The flooring, suitable for foot/vehicular traffic, is formed by installing a cementitious screed (see section [N.5.1.5](#)) according to design specifications, and must be dimensioned to resist the static loads and dynamic stress to which it will be subjected without fracturing, both during site operations and when in service.

If required, embed a layer of reinforcement in the screed (electro-welded mesh or synthetic mesh/fibres). The cementitious screed must include a suitable wear layer, such as a layer of bituminous binder.

Apply a continuous cushioning layer of sheets of foam material around the perimeter of the flooring, to prevent thermal expansion of the flooring pushing against the edges and damaging the vertical turn-ups.

Apply the flooring and reinforcement carefully, if used, to avoid damaging the underlying waterproofing layer.



N.5 WATERPROOFING SYSTEMS FOR FLAT ROOFS BALLASTED WITH A CONCRETE SCREED (SUITABLE FOR FOOT/VEHICULAR TRAFFIC)

N.5.1.1 Application of 2.0 mm-thick synthetic waterproof membrane in PVC-P

Supply and application of UV-resistant and weather-resistant synthetic waterproof membrane in PVC-P (FOR HEAVY VEHICLES: ≥ 2 tonnes/axis) reinforced with dimensionally-stable glass mat (such as **Mapeplan B 20** produced by POLYGLASS S.p.A.), specifically formulated to resist macrobiological attack and bacteria.

The membrane must be produced by “multi-extrusion coating”, a single-step production process which allows the internal reinforcement to be inserted without pre-lamination, and must have a product certificate and marked with the CE symbol in compliance with EN 13956 standards. The effective thickness must be at least 2.0 mm (-5/+10%) according to EN 1849-2 standards.

The material must have the following characteristics:

visible defects according to EN 1850-2:	none
straightness according to EN 1848-2:	≤ 30 mm
flatness according to EN 1848-2:	≤ 10 mm
mass per unit area according to EN 1849-2:	2.5 kg/m^2 (-5/+10%)
impermeability to water according to EN 1928:	≥ 400 kPa/72h
reaction to fire according to EN 13501-1:	Euroclass E
peel strength of welds according to EN 12316-2:	≥ 300 N/50 mm
shear strength of welds according to EN 12317-2:	≥ 500 N/50 mm
vapour diffusion resistance according to EN 1931:	μ ; 19,000
tensile strength according to EN 12311-2:	≥ 9 N/mm ²
elongation at failure according to EN 12311-2:	$\geq 200\%$
impact resistance according to EN 12691:	method A ≥ 900 mm
impact resistance according to EN 12691:	method B ≥ 1000 mm
static puncture resistance CBR according to EN 12730-B:	≥ 20 kg
tear strength according to EN 12310-2:	≥ 100 N
dimensional stability according to EN 1107-2:	$\leq 0.2\%$
foldability at low temperatures according to EN 495-5:	≤ -25 °C
resistance to UV rays according to EN 1297:	compliant: class 0
resistance to root penetration according to EN 13948:	compliant

production certified according to ISO 9001 and ISO 14001 standards.

The membrane must be formulated specifically for application in covered, stratigraphic layers subject to the action of microorganisms, bacteria and roots. Loose-lay membrane, overlap the edges of adjacent sheets by approximately 8 cm and apply a layer of ballast to counteract the suction effect of wind.

Heat-weld the overlaps using a manual and automatic hot-air welder after cleaning them with a specific cleaning product (such as Mapeplan Cleaner produced by POLYGLASS S.p.A.).

Carry out manual heat-welding by spot-welding, internal pre-welding and final external welding to form a weathertight seal.

Included and calculated in the price for work carried out according to specification:

– per square metre

.....(€/m²)

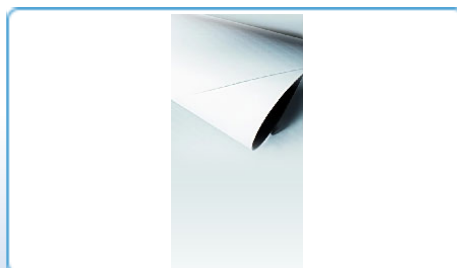

N.5 WATERPROOFING SYSTEMS FOR FLAT ROOFS BALLASTED WITH A CONCRETE SCREED (SUITABLE FOR FOOT/VEHICULAR TRAFFIC)

N.5.1.2 Application of 2.0 mm-thick synthetic waterproof membrane in flexible polyolefin (TPO/FPO)

Supply and application of UV-resistant and weather-resistant synthetic waterproof membrane in flexible polyolefin (TPO/FPO) (FOR HEAVY VEHICLES: ≥ 2 tonnes/axis) reinforced with dimensionally-stable glass mat with a high-reflectance, Smart White surface (such as **Mapeplan T B 20** produced by POLYGLASS S.p.A.). The material must be produced by “multi-extrusion coating”, a single-step production process which allows the internal reinforcement to be inserted without pre-lamination, and must have a product certificate and marked with the CE symbol in compliance with EN 13956 standards.

The effective thickness must be at least 2.0 mm (-5/+10%) according to EN 1849-2 standards.

The product must also have the following characteristics:

visible defects according to EN 1850-2:	none
straightness according to EN 1848-2:	≤ 30 mm
flatness according to EN 1848-2:	≤ 10 mm
mass per unit area according to EN 1849-2:	2.0 kg/m ² (-5/+10%)
impermeability to water according to EN 1928:	≥ 400 kPa/72h
reaction to fire according to EN 13501-1:	Euroclass E
peel strength of welds according to EN 12316-2:	≥ 300 N/50 mm
shear strength of welds according to EN 12317-2:	≥ 500 N/50 mm
vapour diffusion resistance according to EN 1931:	$\geq 150,000$
tensile strength according to EN 12311-2:	≥ 9 N/mm ²
elongation at failure according to EN 12311-2:	$\geq 550\%$
impact resistance according to EN 12691:	method A ≥ 900 mm
impact resistance according to EN 12691:	method B ≥ 1100 mm
static puncture resistance CBR according to EN 12730-B:	≥ 20 kg
tear strength according to EN 12310-2:	≥ 150 N
dimensional stability according to EN 1107-2:	$\leq 0.2\%$
foldability at low temperatures according to EN 495-5:	≤ -35 °C
resistance to UV rays according to EN 1297:	compliant: class 0
resistance to root penetration according to EN 13948:	compliant

production certified according to ISO 9001 and ISO 14001 standards.

The membrane must have a formulation without plasticisers and volatile organic compounds and must have a low impact on the environment and be eco-compatible.

Loose-lay the membrane, overlap the edges of adjacent sheets by approximately 8 cm and apply a layer of ballast to counteract the suction effect of wind.

Heat-weld the overlaps using a manual and automatic hot-air welder after cleaning them with a specific cleaning product (such as Mapeplan T Cleaner produced by POLYGLASS S.p.A.).

Carry out manual heat-welding by spot-welding, internal pre-welding and final external welding to form a weathertight seal.

Included and calculated in the price for work carried out according to specification:

– per square metre

.....(€/m²)

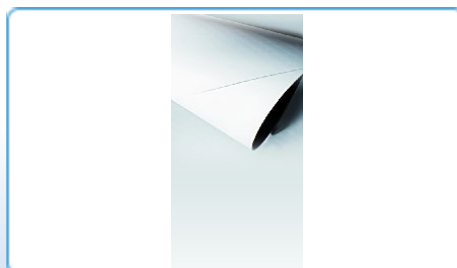

N.5 WATERPROOFING SYSTEMS FOR FLAT ROOFS BALLASTED WITH A CONCRETE SCREED (SUITABLE FOR FOOT/VEHICULAR TRAFFIC)

N.5.1.3 Vertical turn-ups made from 2.0 mm-thick synthetic waterproof membrane in PVC-P

Supply and application of vertical turn-ups for waterproof membranes applied around the edges of roofs, wall fillets, mass fillets, skylights, etc., made from UV-resistant and weather-resistant membrane in PVC-P reinforced with dimensionally-stable glass mat (such as **Mapeplan B 20** produced by POLYGLASS S.p.A.), specifically formulated to resist microbiological attack and bacteria. The material must be produced by “multi-extrusion coating”, a single-step production process which allows the internal reinforcement to be inserted without pre-lamination, and must have a product certificate and marked with the CE symbol in compliance with EN 13956 standards.

The effective thickness must be at least 2.0 mm (-5/+10%) according to EN 1849-2 standards.

Apply the turn-ups by fully-bonding the material to the substrate using a specific contact adhesive (such as **Mapeplan ADS 200** produced by POLYGLASS S.p.A.).

Heat-weld the vertical turn-ups to the membrane using a manual and automatic hot-air welder after cleaning it with a specific cleaning product (such as Mapeplan Cleaner produced by POLYGLASS S.p.A.).

Carry out manual heat-welding by spot-welding, internal pre-welding and final external welding to form a weathertight seal.

Included and calculated in the price for work carried out according to specification:

– per square metre

.....(€/m²)

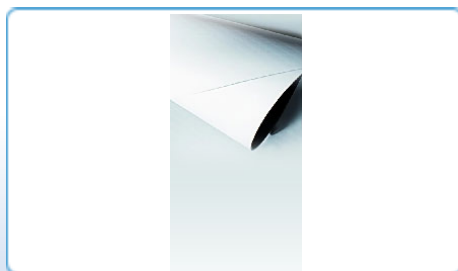

N.5 WATERPROOFING SYSTEMS FOR FLAT ROOFS BALLASTED WITH A CONCRETE SCREED (SUITABLE FOR FOOT/VEHICULAR TRAFFIC)

N.5.1.4 Vertical turn-ups made from 2.0 mm-thick waterproof membrane in flexible polyolefin (TPO/FPO)

Supply and application of vertical turn-ups for waterproof membranes applied around the edges of roofs, wall fillets, mass fillets, skylights, etc., made from UV-resistant and weather-resistant membrane in flexible polyolefin (TPO/FPO) reinforced with dimensionally-stable glass mat, with a high-reflectance, Smart White surface (such as **Mapeplan T B 20** produced by POLYGLASS S.p.A.). The material must be produced by “multi-extrusion coating”, a single-step production process which allows the internal reinforcement to be inserted without pre-lamination, and must have a product certificate and marked with the CE symbol in compliance with EN 13956 standards.

The effective thickness must be at least 2.0 mm (-5/+10%) according to EN 1849-2 standards.

Apply the turn-ups by fully-bonding the material to the substrate using a specific contact adhesive (such as **Mapeplan ADS 300** produced by POLYGLASS S.p.A.).

Heat-weld the vertical turn-ups to the membrane using a manual and automatic hot-air welder after cleaning it with a specific cleaning product (such as Mapeplan T Cleaner produced by POLYGLASS S.p.A.).

Included and calculated in the price for work carried out according to specification:

– *per square metre*(€/m²)

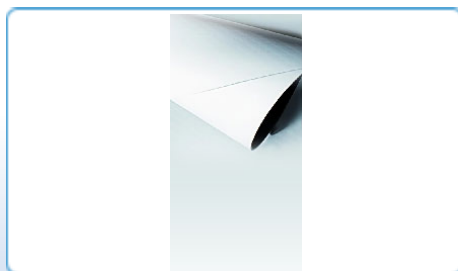

N.5 WATERPROOFING SYSTEMS FOR FLAT ROOFS BALLASTED WITH A CONCRETE SCREED (SUITABLE FOR FOOT/VEHICULAR TRAFFIC)

N.5.1.5 Application of a ballast layer made from a concrete screed

Supply and application of flooring suitable for foot/vehicular traffic made from a cementitious screed according to design specifications, dimensioned to resist the static loads and dynamic stress to which it will be subjected without fracturing, both during site operations and when in service.

If required, embed a layer of reinforcement in the screed (electro-welded mesh or synthetic mesh/fibres). The cementitious screed must include a suitable wear layer, such as a layer of bituminous binder.

Apply a continuous cushioning layer of sheets of foam material around the perimeter of the flooring, to prevent thermal expansion of the flooring pushing against the edges and damaging the vertical turn-ups.

Apply the flooring and reinforcement carefully, if used, to avoid damaging the underlying waterproofing layer.

Included and calculated in the price for work carried out according to specification:

– per square metre

.....(€/m²)

N.5 WATERPROOFING SYSTEMS FOR FLAT ROOFS BALLASTED WITH A CONCRETE SCREED (SUITABLE FOR FOOT/VEHICULAR TRAFFIC)

N.5.2 WATERPROOFING SYSTEMS FOR FLAT ROOFS BALLASTED WITH A CONCRETE SCREED - WARM-ROOF SYSTEM **Procedure**

Preparation of the substrate

Installation and/or checking of reinforced concrete or concrete-masonry substrates with a suitable cement levelling layer to form a slope (see section [N.1.1](#)).

When handed over, substrates must be smooth, clean and dry and all corners and edges must be smooth.

Application of the vapour barrier

After applying a coat of **Polyprimer HP 45** Professional specific primer, supply and application of a vapour barrier by bonding the entire self-adhesive surface of double-adhesive bituminous membrane such as **Polyvap SA** 2.0 mm (see section [N.2.2.1](#)), with overlaps approximately 10 cm wide between adjacent sheets. The membrane is made from a special SBS elastomeric compound with internal aluminium foil reinforcement, and the faces of the membrane are protected by a mono-silicon coated polyethylene film to be peeled when the membrane is applied.

Seal the overlaps between the sheets using a special metal roller.

Application of the insulating layer

Loose-laid self-extinguishing, dimensionally-stable insulating panels made from 200 kPa sintered, expanded polystyrene (EPS) (see section [N.2.2.2](#)) suitable for application on flat roofs, slotted together on all four sides and laid carefully to avoid the formation of thermal bridges. Note: the designer must verify the compressive strength of the insulating panels.

Application of the separation layer

Loose-laid Polydren PES 200 thermo-calendered, 100% polyester non-woven, needle-punched fabric with a weight of 200 g/m², with overlaps approximately 10 cm wide between adjacent sheets (see section [N.2.2.3](#)). Note: not required with TPO/FPO membranes.

Application of the waterproof membrane

PVC-P membranes

- Loose-laid **Mapeplan B 15** (FOR LIGHTWEIGHT TRAFFIC USE: < 2 tonnes/axis) 1.5 mm-thick, UV-resistant and weather-resistant synthetic membrane in PVC-P, reinforced with dimensionally-stable glass mat, specifically formulated to resist macrobiological attack and bacteria, laid with overlaps approximately 8 cm wide between adjacent sheets (see section [N.2.1.2](#)).
- Or, loose-laid **Mapeplan B 20** (FOR HEAVY VEHICLES: ≥ 2 tonnes/axis) 2.0 mm-thick, UV-resistant and weather-resistant synthetic membrane in PVC-P, reinforced with dimensionally-stable glass mat, specifically formulated to resist macrobiological attack and bacteria, laid with overlaps approximately 8 cm wide between adjacent sheets (see section [N.5.1.1](#)).

Heat-weld the overlaps with a manual and automatic hot-air welder after cleaning them with Mapeplan Cleaner.

Carry out manual heat-welding by spot-welding, internal pre-welding and final external welding to form a weathertight seal.

Flexible polyolefin (TPO/FPO) membranes

- Loose-laid **Mapeplan T B 15** (FOR LIGHT VEHICLES: < 2 tonnes/axis) 1.5 mm-thick, UV-resistant and weather-resistant synthetic waterproof membrane in flexible Polyolefin (TPO/FPO) reinforced with dimensionally-stable glass mat, with a high-reflectance, Smart White surface, laid with overlaps approximately 8 cm wide between adjacent sheets (see section **N.2.1.4**).
- Or, loose-laid **Mapeplan T B 20** (FOR HEAVY VEHICLES: ≥ 2 tonnes/axis) 2.0 mm-thick, UV-resistant and weather-resistant synthetic waterproof membrane in flexible polyolefin (TPO/FPO) reinforced with dimensionally-stable glass mat, with a high-reflectance, Smart White surface, laid with overlaps approximately 8 cm wide between adjacent sheets (see section **N.5.1.2**).

Heat-weld the overlaps with a manual and automatic hot-air welder after cleaning them with Mapeplan T Cleaner.

Carry out manual heat-welding by spot-welding, internal pre-welding and final external welding to form a weathertight seal.

Vertical turn-ups

PVC-P membranes

Vertical turn-ups for waterproof membranes around the edges of roofs, wall fillets, mass fillets, skylights, etc. using:

- **Mapeplan B 15** 1.5 mm-thick, UV-resistant and weather-resistant membrane in PVC-P reinforced with dimensionally-stable glass mat (see section **N.2.1.6**) for 1.5 mm thick waterproof membranes.
- **Mapeplan B 20** 2.0 mm-thick, UV-resistant and weather-resistant membrane in PVC-P reinforced with dimensionally-stable glass mat (see section **N.5.1.3**) for 2.0 mm thick waterproof membranes.

Fully-bond the turn-ups to the substrate using **Mapeplan ADS 200**, a specific contact adhesive.

Heat-weld the turn-ups to the membrane with a manual and/or automatic hot-air welder after cleaning them with Mapeplan Cleaner.

Carry out manual heat-welding by spot-welding, internal pre-welding and final external welding to form a weathertight seal.

Flexible Polyolefin (TPO/FPO) membranes

Vertical turn-ups for waterproof membranes around the edges of roofs, wall fillets, mass fillets, skylights, etc. using:

- **Mapeplan T B 15** 1.5 mm-thick, UV-resistant and weather-resistant membrane in flexible polyolefin (TPO/FPO) reinforced with dimensionally-stable glass mat, with a high-reflectance, Smart White surface (see section **N.2.1.8**) for 1.5 mm thick waterproof membranes.
- **Mapeplan T B 20** 2.0 mm-thick, UV-resistant and weather-resistant membrane in flexible polyolefin (TPO/FPO) reinforced with dimensionally-stable glass mat, with a high-reflectance, Smart White surface (see section **N.5.1.4**) for 2.0 mm thick waterproof membranes.

Fully-bond the turn-ups to the substrate using **Mapeplan ADS 300**, a specific contact adhesive.

Heat-weld the turn-ups to the membrane with a manual and automatic hot-air welder after cleaning them with Mapeplan T Cleaner.

Carry out manual heat-welding by spot-welding, internal pre-welding and final external welding to form a weathertight seal.

Perimeter mechanical fixing system

A perimeter fixing system is applied to prevent loose-laid waterproof membranes from moving or being dragged due to variations in temperature, substrate deformation or deformations/movements of the insulating panels, and before applying rigid, heavy layers of ballast (see section [N.4.2.1](#)).

The anti-peeling, linear mechanical fixing system is applied around the perimeter of the roof, skylights, chimney stacks, wall fillets, etc. and fillets between horizontal and vertical surfaces, and comprises:

- Aluzinc-plated, carbon steel anchoring plates suitable for use with waterproof membranes. The plates are treated with a suitable anti-corrosion product and measure 82×40×1 mm.
- Fasteners suitable for the type of substrate (at least 4 fasteners per metre).

Application of the protection layer

Loose-laid **Polydren 500 PP** protection layer in 100% polypropylene non-woven, needle-punched fabric with a weight of 500 g/m², with overlaps approximately 10 cm wide between adjacent sheets (see section [N.2.1.11](#)).

Application of the anti-imbibition flow layer

Loose-laid anti-imbibition flow layer to prevent cement laitance clogging/modifying the underlying layer, made from 0.1 mm-thick, micro-perforated, low-density LDPE polyethylene sheet (such as Mapeplan LDPE Microforato 0.10 mm produced by POLYGLASS S.p.A.), laid with overlaps approximately 10 cm wide between adjacent sheets (see section [N.4.2.2](#)).

Seal the overlaps using single-sided adhesive tape.

Application of the ballast layer

The flooring, suitable for foot/vehicular traffic, is formed by installing a cementitious screed (see section [N.5.1.5](#)) according to design specifications, and must be dimensioned to resist the static loads and dynamic stress to which it will be subjected without fracturing, both during site operations and when in service.

If required, embed a layer of reinforcement in the screed (electro-welded mesh or synthetic mesh/fibres). The cementitious screed must include a suitable wear layer, such as a layer of bituminous binder.

Apply a continuous cushioning layer of sheets of foam material around the perimeter of the flooring, to prevent thermal expansion of the flooring pushing against the edges and damaging the vertical turn-ups.

Apply the flooring and reinforcement carefully, if used, to avoid damaging the underlying waterproofing layer.

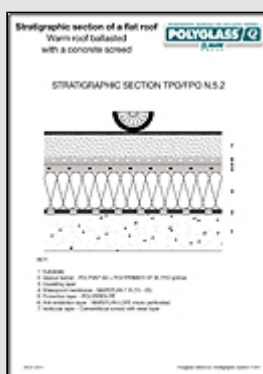
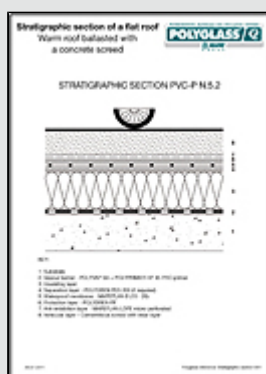

N.6 WATERPROOFING SYSTEMS FOR FLAT ROOFS BALLASTED WITH SOIL (GREEN ROOFS/ROOF GARDENS)

N.6.1 WATERPROOFING SYSTEMS FOR FLAT ROOFS BALLASTED WITH SOIL - COLD-ROOF SYSTEM Procedure

Preparation of the substrate

Installation and/or checking of reinforced concrete or concrete-masonry substrates with a suitable cement levelling layer to form a slope (see section [N.1.1](#)).

When handed over, substrates must be smooth, clean and dry and all corners and edges must be smooth.

Application of the compensation and levelling layer

Loose-laid Polydren 500 PP 100% polypropylene non-woven, needle-punched fabric with a weight of 500 g/m², with overlaps approximately 10 cm wide between adjacent sheets (see section [N.2.1.1](#)).

Application of the waterproof membrane

PVC-P membranes

- Loose-laid **Mapeplan B 15** 1.5 mm-thick, UV-resistant and weather-resistant synthetic membrane in PVC-P, reinforced with dimensionally-stable glass mat, specifically formulated to resist macrobiological attack and bacteria, laid with overlaps approximately 8 cm wide between adjacent sheets (see section [N.2.1.2](#)).
- Or, loose-laid **Mapeplan B 20** 2.0 mm-thick, UV-resistant and weather-resistant synthetic membrane in PVC-P, reinforced with dimensionally-stable glass mat, specifically formulated to resist macrobiological attack and bacteria, laid with overlaps approximately 8 cm wide between adjacent sheets (see section [N.5.1.1](#)).

Heat-weld the overlaps with a manual and automatic hot-air welder after cleaning them with Mapeplan Cleaner.

Carry out manual heat-welding by spot-welding, internal pre-welding and final external welding to form a weathertight seal.

Flexible polyolefin (TPO/FPO) membranes

- Loose-laid **Mapeplan T B 15** 1.5 mm-thick, UV-resistant and weather-resistant synthetic waterproof membrane in flexible Polyolefin (TPO/FPO) reinforced with dimensionally-stable glass mat, with a high-reflectance, Smart White surface, laid with overlaps approximately 8 cm wide between adjacent sheets (see section [N.2.1.4](#)).
- Or, loose-laid **Mapeplan T B 20** 2.0 mm-thick, UV-resistant and weather-resistant synthetic waterproof membrane in flexible polyolefin (TPO/FPO) with a high-reflectance, Smart White surface, reinforced with dimensionally-stable glass mat, laid with overlaps approximately 8 cm wide between adjacent sheets (see section [N.5.1.2](#)).

Heat-weld the overlaps with a manual and automatic hot-air welder after cleaning them with Mapeplan T Cleaner.

Carry out manual heat-welding by spot-welding, internal pre-welding and final external welding to form a weathertight seal.

Vertical turn-ups:**PVC-P membranes**

Vertical turn-ups for waterproof membranes around the edges of roofs, wall fillets, mass fillets, skylights, etc. using:

- **Mapeplan B 15** 1.5 mm-thick, UV-resistant and weather-resistant membrane in PVC-P reinforced with dimensionally-stable glass mat (see section **N.2.1.6**) for 1.5 mm thick waterproof membranes.
- **Mapeplan B 20** 2.0 mm-thick, UV-resistant and weather-resistant membrane in PVC-P reinforced with dimensionally-stable glass mat (see section **N.5.1.3**) for 2.0 mm thick waterproof membranes.

Fully-bond the turn-ups to the substrate using **Mapeplan ADS 200**, a specific contact adhesive.

Heat-weld the turn-ups to the membrane with a manual and/or automatic hot-air welder after cleaning them with Mapeplan Cleaner.

Carry out manual heat-welding by spot-welding, internal pre-welding and final external welding to form a weathertight seal.

Flexible Polyolefin (TPO/FPO) membranes

Vertical turn-ups for waterproof membranes around the edges of roofs, wall fillets, mass fillets, skylights, etc. using:

- **Mapeplan T B 15** 1.5 mm-thick, UV-resistant and weather-resistant membrane in flexible polyolefin (TPO/FPO) reinforced with dimensionally-stable glass mat, with a high-reflectance, Smart White surface (see section **N.2.1.8**) for 1.5 mm thick waterproof membranes.
- **Mapeplan T B 20** 2.0 mm-thick, UV-resistant and weather-resistant membrane in flexible polyolefin (TPO/FPO) reinforced with dimensionally-stable glass mat, with a high-reflectance, Smart White surface (see section **N.5.1.4**) for 2.0 mm thick waterproof membranes.

Fully-bond the turn-ups to the substrate using **Mapeplan ADS 300**, a specific contact adhesive.

Heat-weld the turn-ups to the membrane with a manual and automatic hot-air welder after cleaning them with Mapeplan T Cleaner.

Carry out manual heat-welding by spot-welding, internal pre-welding and final external welding to form a weathertight seal.

Perimeter mechanical fixing system

A perimeter fixing system is applied to prevent loose-laid waterproof membranes from moving or being dragged due to variations in temperature, substrate deformation or deformations/movements of the insulating panels, and before applying rigid, heavy layers of ballast (see section **N.4.2.1**).

The anti-peeling, linear mechanical fixing system is applied around the perimeter of the roof, skylights, chimney stacks, wall fillets, etc. and fillets between horizontal and vertical surfaces, and comprises:

- Aluzinc-plated, carbon steel anchoring plates suitable for use with waterproof membranes. The plates are treated with a suitable anti-corrosion product and measure 82×40×1 mm.
- Fasteners suitable for the type of substrate (at least 4 fasteners per metre).

Application of the protection layer

Loose-laid Polydren 500 PP protection layer in 100% polypropylene non-woven, needle-punched fabric with a weight of 500 g/m², with overlaps approximately 10 cm wide between adjacent sheets (see section [N.2.1.11](#)).

Application of the drainage layer

Application of an even drainage layer for roof gardens, made from washed, round gravel with a grain size of 16 to 32 mm (see section [N.6.1.1](#)). Apply an even layer according to design specifications. Apply the drainage layer carefully to avoid damaging the underlying waterproofing layer.

Application of the filtration layer

Loose-laid filtration layer made from Polydren 200 PES thermo-calendered, 100% polyester non-woven, needle-punched fabric with a weight of 200 g/m², with overlaps approximately 10 cm wide between adjacent sheets (see section [N.6.1.2](#)).

Application of the ballast layer

Application of an even layer of soil suitable for roof gardens (see section [N.6.1.3](#)) according to design specifications. We also recommend forming gravel drainage channels around the perimeter of the roof.

Apply the layer of soil carefully to avoid damaging the underlying waterproofing layer.

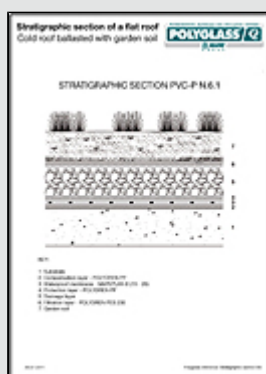

**N.6 WATERPROOFING SYSTEMS FOR FLAT ROOFS BALLASTED WITH SOIL
(GREEN ROOFS/ROOF GARDENS)****N.6.1.1 Application of the gravel drainage layer**

Supply and application an even drainage layer for roof gardens, made from washed, round gravel with a grain size of 16 to 32 mm, according to design specifications. Apply the drainage layer carefully to avoid damaging the underlying waterproofing layer.

Included and calculated in the price for work carried out according to specification:

– per square metre

.....(€/m²)

N.6 WATERPROOFING SYSTEMS FOR FLAT ROOFS BALLASTED WITH SOIL (GREEN ROOFS/ROOF GARDENS)

N.6.1.2 Application of non-woven fabric to form the filtration layer

Filtration layer made from thermo-calendered, 100% polyester non-woven, needle-punched fabric with a weight of 200 g/m² (such as Polydren PES 200 produced by POLYGLASS S.p.A.).

The product must also have the following characteristics:

longitudinal tensile strength according to EN ISO 10319:	3.4 kN/m
transversal tensile strength according to EN ISO 10319:	5.4 kN/m
longitudinal elongation at maximum load according to EN ISO 10319:	100%
transversal elongation at maximum load according to EN ISO 10319:	100%
static puncture resistance CBR according to EN ISO 12236:	0.8 kN
perforation resistance (cone drop test) according to EN ISO 13433:	26 mm

Loose-lay the product and overlap the edges of adjacent sheets by approximately 10 cm.

Included and calculated in the price for work carried out according to specification:

– per square metre(€/m²)

**N.6 WATERPROOFING SYSTEMS FOR FLAT ROOFS BALLASTED WITH SOIL
(GREEN ROOFS/ROOF GARDENS)****N.6.1.3 Application of soil to form the roof garden**

Supply and application of an even layer of soil suitable for roof gardens according to design specifications. We also recommend forming gravel drainage channels around the perimeter of the roof.

Apply the layer of soil carefully to avoid damaging the underlying waterproofing layer.

Included and calculated in the price for work carried out according to specification:

– per square metre(€/m²)

N.6 WATERPROOFING SYSTEMS FOR FLAT ROOFS BALLASTED WITH SOIL (GREEN ROOFS/ROOF GARDENS)

N.6.2 WATERPROOFING SYSTEMS FOR FLAT ROOFS BALLASTED WITH SOIL - WARM-ROOF SYSTEM **Procedure**

Preparation of the substrate

Installation and/or checking of reinforced concrete or concrete-masonry substrates with a suitable cement levelling layer to form a slope (see section [N.1.1](#)).

When handed over, substrates must be smooth, clean and dry and all corners and edges must be smooth.

Application of the vapour barrier

After applying a coat of **Polyprimer HP 45** Professional specific primer, supply and application of a vapour barrier by bonding the entire self-adhesive surface of DOUBLE-ADHESIVE bituminous membrane such as **Polyvap SA** 2.0 mm (see section [N.2.2.1](#)), with overlaps approximately 10 cm wide between adjacent sheets. The membrane is made from a special SBS elastomeric compound with internal aluminium foil reinforcement, and the faces of the membrane are protected by a mono-silicon coated polyethylene film to be peeled off when the membrane is applied.

Seal the overlaps between the sheets using a special metal roller.

Application of the insulating layer

Loose-laid rigid, self-extinguishing, dimensionally-stable insulating panels made from 200 kPa sintered, expanded polystyrene (EPS) (see section [N.2.2.2](#)) suitable for application on flat roofs, slotted together on all four sides and laid carefully to avoid the formation of thermal bridges.

Application of the separation layer

Loose-laid Polydren PES 200 thermo-calendered, 100% polyester non-woven, needle-punched fabric with a weight of 200 g/m², with overlaps approximately 10 cm wide between adjacent sheets (see section [N.2.2.3](#)). Note: not required with TPO/FPO membranes.

Application of the waterproof membrane

PVC-P membranes

- Loose-laid **Mapeplan B 15** 1.5 mm-thick, UV-resistant and weather-resistant synthetic membrane in PVC-P, reinforced with dimensionally-stable glass mat, specifically formulated to resist macrobiological attack and bacteria, laid with overlaps approximately 8 cm wide between adjacent sheets (see section [N.2.1.2](#)).
- Or, loose-laid **Mapeplan B 20** 2.0 mm-thick, UV-resistant and weather-resistant synthetic membrane in PVC-P, reinforced with dimensionally-stable glass mat, specifically formulated to resist macrobiological attack and bacteria, laid with overlaps approximately 8 cm wide between adjacent sheets (see section [N.5.1.1](#)).

Heat-weld the overlaps with a manual and automatic hot-air welder after cleaning them with Mapeplan Cleaner.

Carry out manual heat-welding by spot-welding, internal pre-welding and final external welding to form a weathertight seal.

Flexible polyolefin (TPO/FPO) membranes

- Loose-laid **Mapeplan T B 15** 1.5 mm-thick, UV-resistant and weather-resistant synthetic waterproof membrane in flexible Polyolefin (TPO/FPO) reinforced with dimensionally-stable glass mat, with a high-reflectance, Smart White surface, laid with overlaps approximately 8 cm wide between adjacent sheets (see section **N.2.1.4**).
- Or, loose-laid **Mapeplan T B 20** 2.0 mm-thick, UV-resistant and weather-resistant synthetic waterproof membrane in flexible polyolefin (TPO/FPO) reinforced with dimensionally-stable glass mat, with a high-reflectance, Smart White surface, laid with overlaps approximately 8 cm wide between adjacent sheets (see section **N.5.1.2**).

Heat-weld the overlaps with a manual and automatic hot-air welder after cleaning them with Mapeplan T Cleaner.

Carry out manual heat-welding by spot-welding, internal pre-welding and final external welding to form a weathertight seal.

Vertical turn-ups:

PVC-P membranes

Vertical turn-ups for waterproof membranes around the edges of roofs, wall fillets, mass fillets, skylights, etc. using:

- **Mapeplan B 15** 1.5 mm-thick, UV-resistant and weather-resistant membrane in PVC-P reinforced with dimensionally-stable glass mat (see section **N.2.1.6**) for 1.5 mm thick waterproof membranes;
- **Mapeplan B 20** 2.0 mm-thick, UV-resistant and weather-resistant membrane in PVC-P reinforced with dimensionally-stable glass mat (see section **N.5.1.3**) for 2.0 mm thick waterproof membranes.

Fully-bond the turn-ups to the substrate using **Mapeplan ADS 200**, a specific contact adhesive.

Heat-weld the turn-ups to the membrane with a manual and/or automatic hot-air welder after cleaning them with Mapeplan Cleaner.

Carry out manual heat-welding by spot-welding, internal pre-welding and final external welding to form a weathertight seal.

Flexible Polyolefin (TPO/FPO) membranes

Vertical turn-ups for waterproof membranes around the edges of roofs, wall fillets, mass fillets, skylights, etc. using:

- **Mapeplan T B 15** 1.5 mm-thick, UV-resistant and weather-resistant membrane in flexible polyolefin (TPO/FPO) reinforced with dimensionally-stable glass mat, with a high-reflectance, Smart White surface (see section **N.2.1.8**) for 1.5 mm thick waterproof membranes;
- **Mapeplan T B 20** 2.0 mm-thick, UV-resistant and weather-resistant membrane in flexible polyolefin (TPO/FPO) reinforced with dimensionally-stable glass mat, with a high-reflectance, Smart White surface (see section **N.5.1.4**) for 2.0 mm thick waterproof membranes.

Fully-bond the turn-ups to the substrate using **Mapeplan ADS 300**, a specific contact adhesive.

Heat-weld the turn-ups to the membrane with a manual and automatic hot-air welder after cleaning them with Mapeplan T Cleaner.

Carry out manual heat-welding by spot-welding, internal pre-welding and final external welding to form a weathertight seal.

Perimeter mechanical fixing system

A perimeter fixing system is applied to prevent loose-laid waterproof membranes from moving or being dragged due to variations in temperature, substrate deformation or deformations/movements of the insulating panels, and before applying rigid, heavy layers of ballast (see section [N.4.2.1](#)).

The anti-peeling, linear mechanical fixing system is applied around the perimeter of the roof, skylights, chimney stacks, wall fillets, etc. and fillets between horizontal and vertical surfaces, and comprises:

- Aluzinc-plated, carbon steel anchoring plates suitable for use with waterproof membranes. The plates are treated with a suitable anti-corrosion product and measure 82x40x1 mm;
- Fasteners suitable for the type of substrate (at least 4 fasteners per metre).

Application of the protection layer

Loose-laid **Polydren 500 PP** protection layer in 100% polypropylene non-woven, needle-punched fabric with a weight of 500 g/m², with overlaps approximately 10 cm wide between adjacent sheets (see section [N.2.1.11](#)).

Application of the drainage layer

Application of an even drainage layer for roof gardens, made from washed, round gravel with a grain size of 16 to 32 mm (see section [N.6.1.1](#)). Apply an even layer according to design specifications. Apply the drainage layer carefully to avoid damaging the underlying waterproofing layer.

Application of the filtration layer

Loose-laid filtration layer made from Polydren 200 PES 100% polyester non-woven, needle-punched fabric with a weight of 200 g/m², with overlaps approximately 10 cm wide between adjacent sheets (see section [N.6.1.2](#)).

Application of the ballast layer

Application of an even layer of soil suitable for roof gardens (see section [N.6.1.3](#)) according to design specifications. We also recommend forming gravel drainage channels around the perimeter of the roof.

Apply the layer of soil carefully to avoid damaging the underlying waterproofing layer.

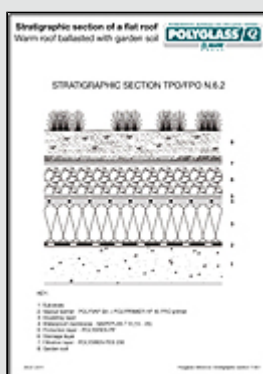
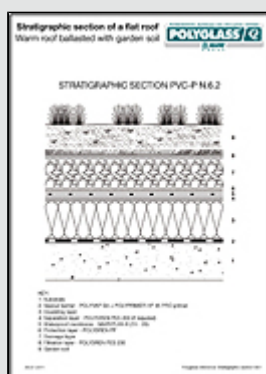

N.7.1 ADHERED WATERPROOFING SYSTEMS FOR EXPOSED FLAT ROOFS - COLD-ROOF SYSTEM
Procedure**Preparation of the substrate**

Installation and/or checking of reinforced concrete or concrete-masonry substrates with a suitable cement levelling layer to form a slope (see section **N.1.1**).

When handed over, substrates must be smooth, clean and dry and all corners and edges must be smooth.

Application of the waterproof membrane**PVC-P membranes**

- Application by full-bonding of **Mapeplan Af** 15 1.5 mm-thick, UV-resistant and weather-resistant synthetic waterproof membrane in PVC-P reinforced with dimensionally-stable glass mat, with 300 g/m² non-woven, 100% polyester fleece backing, with overlaps between adjacent sheets approximately 5 cm-wide (see section **N.7.1.1**).
- Or, fully-bonded **Mapeplan Af** 18 1.8 mm-thick, UV-resistant and weather-resistant synthetic waterproof membrane in PVC-P reinforced with dimensionally-stable glass mat, with 300 g/m² non-woven, 100% polyester fleece backing, with overlaps between adjacent sheets approximately 5 cm-wide (see section **N.7.1.2**).

Fully-bond the sheets to counteract the suction effect of wind using **Mapeplan ADS 100** one-component, synthetic polyurethane adhesive.

Heat-weld the overlaps with a manual and automatic hot-air welder after cleaning them with Mapeplan Cleaner.

Carry out manual heat-welding by spot-welding, internal pre-welding and final external welding to form a weathertight seal.

Flexible polyolefin (TPO/FPO) membranes

- Application by full-bonding of **Mapeplan T Af** 15 1.5 mm-thick, UV-resistant and weather-resistant synthetic waterproof membrane in flexible polyolefin (TPO/FPO) reinforced with dimensionally-stable glass mat, with 300 g/m² non-woven, 100% polyester fleece backing, with overlaps between adjacent sheets approximately 5 cm-wide (see section **N.7.1.3**).
- Or, fully-bonded **Mapeplan T Af** 18 1.8 mm-thick, UV-resistant and weather-resistant synthetic waterproof membrane in flexible polyolefin (TPO/FPO) reinforced with dimensionally-stable glass mat, with 300 g/m² non-woven, 100% polyester fleece backing, with overlaps between adjacent sheets approximately 5 cm-wide (see section **N.7.1.4**).

Fully-bond the sheets to counteract the suction effect of wind using **Mapeplan ADS 100** one-component, synthetic polyurethane adhesive.

Heat-weld the overlaps with a manual and automatic hot-air welder after cleaning them with Mapeplan T Cleaner.

Carry out manual heat-welding by spot-welding, internal pre-welding and final external welding to form a weathertight seal.

Vertical turn-ups

PVC-P membranes

Vertical turn-ups for waterproof membranes around the edges of roofs, wall fillets, mass fillets, skylights, etc. using:

- **Mapeplan B** 15 1.5 mm-thick, UV-resistant and weather-resistant membrane in PVC-P reinforced with dimensionally-stable glass mat (see section [N.2.1.6](#)) for 1.5 mm thick waterproof membranes;
- **Mapeplan B** 18 1.8 mm-thick, UV-resistant and weather-resistant membrane in PVC-P reinforced with dimensionally-stable glass mat (see section [N.2.1.7](#)) for 1.8 mm thick waterproof membranes.

Fully-bond the turn-ups to the substrate using **Mapeplan ADS 200**, a specific contact adhesive.

Heat-weld the turn-ups to the membrane with a manual and/or automatic hot-air welder after cleaning them with Mapeplan Cleaner.

Carry out manual heat-welding by spot-welding, internal pre-welding and final external welding to form a weathertight seal.

Flexible polyolefin (TPO/FPO) membranes

Vertical turn-ups for waterproof membranes around the edges of roofs, wall fillets, mass fillets, skylights, etc. using:

- **Mapeplan T B** 15 1.5 mm-thick, UV-resistant and weather-resistant membrane in flexible polyolefin (TPO/FPO) reinforced with dimensionally-stable glass mat, with a high-reflectance, Smart White surface (see section [N.2.1.8](#)) for 1.5 mm thick waterproof membranes;
- **Mapeplan T B** 18 1.8 mm-thick, UV-resistant and weather-resistant membrane in flexible Polyolefin (TPO/FPO) reinforced with dimensionally-stable glass mat, with a high-reflectance, Smart White surface (see section [N.2.1.9](#)) for 1.8 mm thick waterproof membranes.

Fully-bond the turn-ups to the substrate using **Mapeplan ADS 300**, a specific contact adhesive.

Heat-weld the turn-ups to the membrane with a manual and automatic hot-air welder after cleaning them with Mapeplan T Cleaner.

Carry out manual heat-welding by spot-welding, internal pre-welding and final external welding to form a weathertight seal.

Perimeter mechanical fixing system

A linear perimeter fixing system is applied to prevent loose-laid waterproof membranes from moving or being dragged due to variations in temperature, substrate deformation or deformations/movements of the insulating panels or underlying materials.

The fixing system (see section **N.2.1.10**) is applied around the perimeter of the roof, skylights, chimney stacks, wall fillets, etc. and fillets between horizontal and vertical surfaces, and comprises:

- Mapeplan Metalbar pre-punched, zinc-plated, carbon steel profiled fastening bars;
- Fasteners suitable for the type of substrate (at least 4 fasteners per metre);
- 4 mm-diameter, anti-tear seaming cord applied around the Mapeplan Metalbar profiles by hot-air welding to the Mapeplan waterproof membrane.



N.7 ADHERED WATERPROOFING SYSTEMS FOR EXPOSED FLAT ROOFS

N.7.1.1 Application of 1.5 mm-thick synthetic waterproof membrane in PVC-P

Supply and application of UV-resistant and weather-resistant synthetic waterproof membrane in PVC-P reinforced with dimensionally-stable glass mat and with 300 g/m² non-woven, 100% polyester fleece backing (such as **Mapeplan Af 15** produced by POLYGLASS S.p.A.). The material must be produced by “multi-extrusion coating”, a single-step production process which allows the internal reinforcement to be inserted without pre-lamination, and must have a product certificate and marked with the CE symbol in compliance with EN 13956 standards.

The effective thickness must be at least 1.5 mm (-5/+10%) according to EN 1849-2 standards.

The material must have the following characteristics:

visible defects according to EN 1850-2:	none
straightness according to EN 1848-2:	≤ 30 mm
flatness according to EN 1848-2:	≤ 10 mm
mass per unit area according to EN 1849-2:	2.1 kg/m ² (-5/+10%)
impermeability to water according to EN 1928:	≥ 400 kPa/72h
reaction to fire according to EN 13501-1:	Euroclass E
resistance to hail according to EN 13583:	rigid substrates: ≥ 20 m/s
resistance to hail according to EN 13583:	soft substrates: ≥ 30 m/s
peel strength of welds according to EN 12316-2:	≥ 300 N/50 mm
shear strength of welds according to EN 12317-2:	≥ 500 N/50 mm
vapour diffusion resistance according to EN 1931:	μ 19,000
tensile strength according to EN 12311-2:	≥ 700 N/50 mm
elongation at failure according to EN 12311-2:	≥ 65%
impact resistance according to EN 12691:	method A ≥ 600 mm
impact resistance according to EN 12691:	method B ≥ 850 mm
static puncture resistance CBR according to EN 12730-B:	≥ 20 kg
tear strength according to EN 12310-2:	≥ 150 N
dimensional stability according to EN 1107-2:	≤ 0.2%
foldability at low temperatures according to EN 495-5:	≤ -25°C
resistance to UV rays according to EN 1297:	compliant: class 0

production certified according to ISO 9001 and ISO 14001 standards.

The product must be specifically formulated for application on fully-exposed flat roofs using the full-bonding technique. Fully-bond the sheets to counteract the suction effect of wind using one-component, synthetic polyurethane adhesive (such as **Mapeplan ADS 100** produced by POLYGLASS S.p.A.), with overlaps approximately 5 cm wide between adjacent sheets. Heat-weld the overlaps using a manual and automatic hot-air welder after cleaning them with a specific cleaning product (such as Mapeplan Cleaner produced by POLYGLASS S.p.A.). Carry out manual heat-welding by spot-welding, internal pre-welding and final external welding to form a weathertight seal.

Included and calculated in the price for work carried out according to specification:

– per square metre

.....(€/m²)

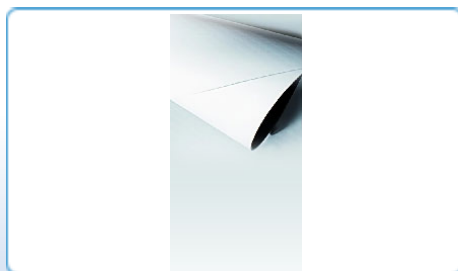

N.7 ADHERED WATERPROOFING SYSTEMS FOR EXPOSED FLAT ROOFS

N.7.1.2 Application of 1.8 mm-thick synthetic waterproof membrane in PVC-P

Supply and application of UV-resistant and weather-resistant synthetic waterproof membrane in PVC-P reinforced with dimensionally-stable glass mat and with 300 g/m² non-woven, 100% polyester fleece backing (such as **Mapeplan Af** 18 produced by POLYGLASS S.p.A.). The material must be produced by “multi-extrusion coating”, a single-step production process which allows the internal reinforcement to be inserted without pre-lamination, and must have a product certificate and marked with the CE symbol in compliance with EN 13956 standards.

The effective thickness must be at least 1.8 mm (-5/+10%) according to EN 1849-2 standards.

The material must have the following characteristics:

visible defects according to EN 1850-2:	none
straightness according to EN 1848-2:	≤ 30 mm
flatness according to EN 1848-2:	≤ 10 mm
mass per unit area according to EN 1849-2:	2.5 kg/m ² (-5/+10%)
impermeability to water according to EN 1928:	≥ 400 kPa/72h
reaction to fire according to EN 13501-1:	Euroclass E
resistance to hail according to EN 13583:	rigid substrates: ≥ 20 m/s
resistance to hail according to EN 13583:	soft substrates: ≥ 33 m/s
peel strength of welds according to EN 12316-2:	≥ 300 N/50 mm
shear strength of welds according to EN 12317-2:	≥ 500 N/50 mm
vapour diffusion resistance according to EN 1931:	μ 19,000
tensile strength according to EN 12311-2:	≥ 800 N/50 mm
elongation at failure according to EN 12311-2:	≥ 65%
impact resistance according to EN 12691:	method A ≥ 800 mm
impact resistance according to EN 12691:	method B ≥ 950 mm
static puncture resistance CBR according to EN 12730-B:	≥ 20 kg
tear strength according to EN 12310-2:	≥ 150 N
dimensional stability according to EN 1107-2:	≤ 0.2%
foldability at low temperatures according to EN 495-5:	≤ -25°C
resistance to UV rays according to EN 1297:	compliant: class 0

production certified according to ISO 9001 and ISO 14001 standards.

The product must be specifically formulated for application on fully-exposed flat roofs using the full-bonding technique. Fully-bond the sheets to counteract the suction effect of wind using one-component, synthetic polyurethane adhesive (such as **Mapeplan ADS 100** produced by POLYGLASS S.p.A.), with overlaps approximately 5 cm wide between adjacent sheets. Heat-weld the overlaps using a manual and automatic hot-air welder after cleaning them with a specific cleaning product (such as Mapeplan Cleaner produced by POLYGLASS S.p.A.). Carry out manual heat-welding by spot-welding, internal pre-welding and final external welding to form a weathertight seal.

Included and calculated in the price for work carried out according to specification:

– per square metre

.....(€/m²)

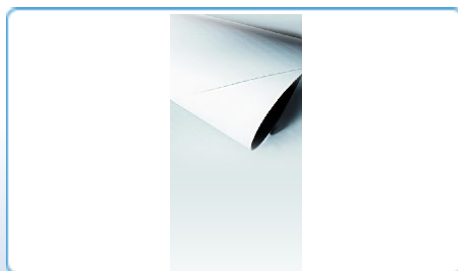

N.7 ADHERED WATERPROOFING SYSTEMS FOR EXPOSED FLAT ROOFS

N.7.1.3 Application of 1.5 mm-thick synthetic waterproof membrane in flexible polyolefin (TPO/FPO)

Supply and application of UV-resistant and weather-resistant synthetic waterproof membrane in flexible polyolefin (TPO/FPO) reinforced with dimensionally-stable glass mat, with a 300 g/m² non-woven, 100% polyester fleece backing and a high-reflectance, Smart White surface (such as **Mapeplan T Af 15** produced by POLYGLASS S.p.A.). The material must be produced by “multi-extrusion coating”, a single-step production process which allows the internal reinforcement to be inserted without pre-lamination, and must have a product certificate and marked with the CE symbol in compliance with EN 13956 standards.

The effective thickness must be at least 1.5 mm (-5/+10%) according to EN 1849-2 standards.

The material must have the following characteristics:

visible defects according to EN 1850-2:	none
straightness according to EN 1848-2:	≤ 30 mm
flatness according to EN 1848-2:	≤ 10 mm
mass per unit area according to EN 1849-2:	1.8 kg/m ² (-5/+10%)
impermeability to water according to EN 1928:	≥ 400 kPa/72h
reaction to fire according to EN 13501-1:	Euroclass E
resistance to hail according to EN 13583:	rigid substrates: ≥ 22 m/s
resistance to hail according to EN 13583:	soft substrates: ≥ 30 m/s
peel strength of welds according to EN 12316-2:	≥ 300 N/50 mm
shear strength of welds according to EN 12317-2:	≥ 500 N/50 mm
vapour diffusion resistance according to EN 1931:	μ 150,000
tensile strength according to EN 12311-2:	≥ 700 N/50 mm
elongation at failure according to EN 12311-2:	≥ 65%
impact resistance according to EN 12691:	method A ≥ 600 mm
impact resistance according to EN 12691:	method B ≥ 900 mm
static puncture resistance CBR according to EN 12730-B:	≥ 20 kg
tear strength according to EN 12310-2:	≥ 200 N
dimensional stability according to EN 1107-2:	≤ 0.2%
foldability at low temperatures according to EN 495-5:	≤ -35 °C
resistance to UV rays according to EN 1297:	compliant: class 0
production certified according to ISO 9001 and ISO 14001 standards.	

The product must be specifically formulated for application on fully-exposed flat roofs using the full-bonding technique. Fully-bond the sheets to counteract the suction effect of wind using one-component, synthetic polyurethane adhesive (such as **Mapeplan ADS 100** produced by POLYGLASS S.p.A.), with overlaps approximately 5 cm wide between adjacent sheets. Heat-weld the overlaps using a manual and automatic hot-air welder after cleaning them with a specific cleaning product (such as Mapeplan T Cleaner produced by POLYGLASS S.p.A.). Carry out manual heat-welding by spot-welding, internal pre-welding and final external welding to form a weathertight seal.

Included and calculated in the price for work carried out according to specification:

– per square metre

.....(€/m²)

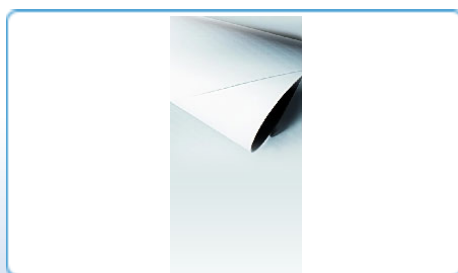

N.7 ADHERED WATERPROOFING SYSTEMS FOR EXPOSED FLAT ROOFS

N.7.1.4 Application of 1.8 mm-thick synthetic waterproof membrane in flexible polyolefin (TPO/FPO)

Supply and application of UV-resistant and weather-resistant synthetic waterproof membrane in flexible polyolefin (TPO/FPO) reinforced with dimensionally-stable glass mat, with a 300 g/m² non-woven, 100% polyester fleece backing and a high-reflectance, Smart White surface (such as **Mapeplan T Af 18** produced by POLYGLASS S.p.A.). The material must be produced by “multi-extrusion coating”, a single-step production process which allows the internal reinforcement to be inserted without pre-lamination, and must have a product certificate and marked with the CE symbol in compliance with EN 13956 standards.

The effective thickness must be at least 1.8 mm (-5/+10%) according to EN 1849-2 standards.

The material must have the following characteristics:

visible defects according to EN 1850-2:	none
straightness according to EN 1848-2:	≤ 30 mm
flatness according to EN 1848-2:	≤ 10 mm
mass per unit area according to EN 1849-2:	2.1 kg/m ² (-5/+10%)
impermeability to water according to EN 1928:	≥ 400 kPa/72h
reaction to fire according to EN 13501-1:	Euroclass E
resistance to hail according to EN 13583:	rigid substrates: ≥ 25 m/s
resistance to hail according to EN 13583:	soft substrates: ≥ 33 m/s
peel strength of welds according to EN 12316-2:	≥ 300 N/50 mm
shear strength of welds according to EN 12317-2:	≥ 500 N/50 mm
vapour diffusion resistance according to EN 1931:	μ 150,000
tensile strength according to EN 12311-2:	≥ 800 N/50 mm
elongation at failure according to EN 12311-2:	≥ 65%
impact resistance according to EN 12691:	method A ≥ 800 mm
impact resistance according to EN 12691:	method B ≥ 1000 mm
static puncture resistance CBR according to EN 12730-B:	≥ 20 kg
tear strength according to EN 12310-2:	≥ 200 N
dimensional stability according to EN 1107-2:	≤ 0.2%
foldability at low temperatures according to EN 495-5:	≤ -35 °C
resistance to UV rays according to EN 1297:	compliant: class 0
production certified according to ISO 9001 and ISO 14001 standards.	

The product must be specifically formulated for application on fully-exposed flat roofs using the full-bonding technique. Fully-bond the sheets to counteract the suction effect of wind using one-component, synthetic polyurethane adhesive (such as **Mapeplan ADS 100** produced by POLYGLASS S.p.A.), with overlaps approximately 5 cm wide between adjacent sheets. Heat-weld the overlaps using a manual and automatic hot-air welder after cleaning them with a specific cleaning product (such as Mapeplan T Cleaner produced by POLYGLASS S.p.A.). Carry out manual heat-welding by spot-welding, internal pre-welding and final external welding to form a weathertight seal.

Included and calculated in the price for work carried out according to specification:

– per square metre

.....(€/m²)

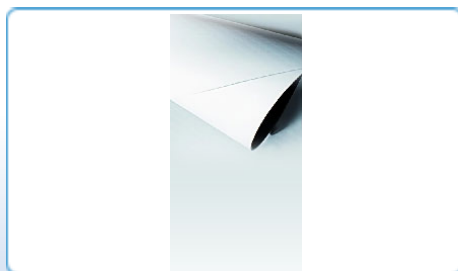

**N.7.2 ADHERED WATERPROOFING SYSTEMS FOR EXPOSED FLAT ROOFS - WARM-ROOF SYSTEM
Procedure****Preparation of the substrate**

Installation and/or checking of reinforced concrete or concrete-masonry substrates with a suitable cement levelling layer to form a slope (see section **N.1.1**).

When handed over, substrates must be smooth, clean and dry and all corners and edges must be smoothed.

Application of the vapour barrier

After applying a coat of **Polyprimer HP 45** Professional specific primer, supply and application of a vapour barrier by bonding the entire self-adhesive surface of double-adhesive bituminous membrane such as **Polyvap SA** 2.0 mm (see section **N.2.2.1**), with overlaps approximately 10 cm wide between adjacent sheets. The membrane is made from a special SBS elastomeric compound with internal aluminium foil reinforcement, and the faces of the membrane are protected by a mono-silicon coated polyethylene film to be peeled when the membrane is applied.

Seal the overlaps between the sheets using a special metal roller.

Application of the insulating layer

- Bonding of rigid, self-extinguishing, dimensionally-stable insulating panels made from 150 kPa sintered expanded polystyrene (EPS) (see section **N.7.2.1**). Make sure the panels are laid carefully and butted together perfectly to avoid forming thermal bridges.
- Or, loose-laid rigid, self-extinguishing, dimensionally-stable insulating panels made from 150 kPa sintered, expanded polystyrene (EPS), slotted together on all four sides and laid carefully to avoid the formation of thermal bridges.

Each panel is then fixed in place using special metal plates and fasteners (screws, plugs, etc.) suitable for the substrate, and treated with a product to prevent corrosion **N.7.2.2**.

If in doubt, we recommend carrying out preliminary pull-out tests directly on site.

Application of the waterproof membrane**PVC-P membranes**

- Application by full-bonding of **Mapeplan Af 15** 1.5 mm-thick, UV-resistant and weather-resistant synthetic waterproof membrane in PVC-P reinforced with dimensionally-stable glass mat, with 300 g/m² non-woven, 100% polyester fleece backing, with overlaps between adjacent sheets approximately 5 cm-wide (see section **N.7.1.1**).
- Or, fully-bonded **Mapeplan Af 18** 1.8 mm-thick, UV-resistant and weather-resistant synthetic waterproof membrane in PVC-P reinforced with dimensionally-stable glass mat, with 300 g/m² non-woven, 100% polyester fleece backing, with overlaps between adjacent sheets approximately 5 cm-wide (see section **N.7.1.2**).

Fully-bond the sheets to counteract the suction effect of wind using **Mapeplan ADS 100** one-component, synthetic polyurethane adhesive.

Heat-weld the turn-ups to the membrane with a manual and/or automatic hot-air welder after cleaning them with Mapeplan Cleaner.

Carry out manual heat-welding by spot-welding, internal pre-welding and final external welding to form a weathertight seal.

Flexible polyolefin (TPO/FPO) membranes

- Application by full-bonding of **Mapeplan T Af 15** 1.5 mm-thick, UV-resistant and weather-resistant synthetic waterproof membrane in flexible polyolefin (TPO/FPO) reinforced with dimensionally-stable glass mat, with 300 g/m² non-woven, 100% polyester fleece backing, with overlaps between adjacent sheets approximately 5 cm-wide (see section **N.7.1.3**).
- Or, fully-bonded **Mapeplan T Af 18** 1.8 mm-thick, UV-resistant and weather-resistant synthetic waterproof membrane in flexible polyolefin (TPO/FPO) reinforced with dimensionally-stable glass mat, with 300 g/m² non-woven, 100% polyester fleece backing, with overlaps between adjacent sheets approximately 5 cm-wide (see section **N.7.1.4**).

Fully-bond the sheets to counteract the suction effect of wind using **Mapeplan ADS 100** one-component, synthetic polyurethane adhesive.

Heat-weld the overlaps with a manual and automatic hot-air welder after cleaning them with Mapeplan T Cleaner.

Carry out manual heat-welding by spot-welding, internal pre-welding and final external welding to form a weathertight seal.

Vertical turn-ups

PVC-P membranes

Vertical turn-ups for waterproof membranes around the edges of roofs, wall fillets, mass fillets, skylights, etc. using:

- **Mapeplan B 15** 1.5 mm-thick, UV-resistant and weather-resistant membrane in PVC-P reinforced with dimensionally-stable glass mat (see section **N.2.1.6**) for 1.5 mm thick waterproof membranes;
- **Mapeplan B 18** 1.8 mm-thick, UV-resistant and weather-resistant membrane in PVC-P reinforced with dimensionally-stable glass mat (see section **N.2.1.7**) for 1.8 mm thick waterproof membranes.

Fully-bond the turn-ups to the substrate using **Mapeplan ADS 200**, a specific contact adhesive.

Heat-weld the turn-ups to the membrane with a manual and/or automatic hot-air welder after cleaning them with Mapeplan Cleaner.

Carry out manual heat-welding by spot-welding, internal pre-welding and final external welding to form a weathertight seal.

Flexible polyolefin (TPO/FPO) membranes

Vertical turn-ups for waterproof membranes around the edges of roofs, wall fillets, mass fillets, skylights, etc. using:

- **Mapeplan T B 15** 1.5 mm-thick, UV-resistant and weather-resistant membrane in flexible polyolefin (TPO/FPO) reinforced with dimensionally-stable glass mat, with a high-reflectance, Smart White surface (see section **N.2.1.8**) for 1.5 mm thick waterproof membranes;
- **Mapeplan T B 18** 1.8 mm-thick, UV-resistant and weather-resistant membrane in flexible Polyolefin (TPO/FPO) reinforced with dimensionally-stable glass mat, with a high-reflectance, Smart White surface (see section **N.2.1.9**) for 1.8 mm thick waterproof membranes.

Fully-bond the turn-ups to the substrate using **Mapeplan ADS 300**, a specific contact adhesive.

Heat-weld the turn-ups to the membrane with a manual and automatic hot-air welder after cleaning them with Mapeplan T Cleaner.

Carry out manual heat-welding by spot-welding, internal pre-welding and final external welding to form a weathertight seal.

Perimeter mechanical fixing system

A linear perimeter fixing system is applied to prevent loose-laid waterproof membranes from moving or being dragged due to variations in temperature, substrate deformation or deformations/movements of the insulating panels or underlying materials.

The fixing system (see section **N.2.1.10**) is applied around the perimeter of the roof, skylights, chimney stacks, wall fillets, etc. and fillets between horizontal and vertical surfaces, and comprises:

- Mapeplan Metalbar pre-punched, zinc-plated, carbon steel profiled fastening bars;
- Fasteners suitable for the type of substrate (at least 4 fasteners per metre);
- 4 mm-diameter, anti-tear seaming cord applied around the Mapeplan Metalbar profiles by hot-air welding to the Mapeplan waterproof membrane.



N.7 ADHERED WATERPROOFING SYSTEMS FOR EXPOSED FLAT ROOFS**N.7.2.1 Application of the insulating layer in 150 kPa sintered expanded polystyrene by bonding**

Supply and application of 150 kPa rigid, self-extinguishing, dimensionally-stable insulation panels suitable for flat roofs, made from sintered expanded polystyrene (EPS). The panels must be made from non-recycled, virgin raw materials with CE certification in compliance with EN 13163 standards.

The material must have the following characteristics:

definition according to EN 13163:	EPS 150
thermal conductivity λ according to EN 13163:	0.035 W/mK
thickness:	XXX mm
compressive strength (10% deformation) according to EN 826:	150 kPa
fire resistance class according to EN 13501-1:	Euroclass E

Bond the panels in place and make sure they are well butted together to prevent the formation of thermal bridges.

Included and calculated in the price for work carried out according to specification:

– per square metre(€/m²)

N.7 ADHERED WATERPROOFING SYSTEMS FOR EXPOSED FLAT ROOFS**N.7.2.2 Application of the insulating layer in 150 kPa sintered expanded polystyrene by slotting them together on all four sides and fixing them in place mechanically**

Supply and application of 150 kPa rigid insulation panels made from self-extinguishing, dimensionally-stable, extruded polystyrene foam (EPS), suitable for exposed flat roofs with a waterproof membrane. The panels must be made from non-recycled, virgin raw materials with CE certification in compliance with EN 13163 standards.

The material must have the following characteristics:

definition according to EN 13163:	EPS 150 kPa
thermal conductivity λ according to EN 13163:	0.035 W/mK
thickness:	XXX mm
compressive strength (10% deformation) according to EN 826:	150 kPa
fire resistance class according to EN 13501-1:	Euroclass E
approximate density:	25 kg/m ³

Apply the panels by slotting them together on all four sides, and make sure they are well butted together to prevent the formation of thermal bridges.

Each panel is then fixed in place using special metal plates and fasteners (screws, plugs, etc.) suitable for the substrate, and treated with a product to prevent corrosion.

If in doubt, we recommend carrying out preliminary pull-out tests directly on site.

Included and calculated in the price for work carried out according to specification:

– per square metre(€/m²)

N.8 MECHANICALLY-FIXED WATERPROOFING SYSTEMS FOR EXPOSED FLAT ROOFS

N.8.1 MECHANICALLY-FIXED WATERPROOFING SYSTEMS FOR EXPOSED FLAT ROOFS - COLD-ROOF SYSTEM **Procedure**

Preparation of the substrate

Installation and/or checking of reinforced concrete or concrete-masonry substrates with a suitable cement levelling layer to form a slope (see section [N.1.1](#)).

When handed over, substrates must be smooth, clean and dry and all corners and edges must be smoothed.

Application of the compensation and levelling layer

Loose-laid Polydren 500 PP 100% polypropylene non-woven, needle-punched fabric with a weight of 500 g/m², with overlaps approximately 10 cm wide between adjacent sheets (see section [N.2.1.1](#)).

Application of the waterproof membrane

PVC-P membranes

- Loose-laid **Mapeplan M 15** 1.5 mm-thick, UV-resistant and weather-resistant synthetic membrane in PVC-P, reinforced with high-strength polyester mat (see section [N.8.1.1](#)), with overlaps approximately 12 cm wide between adjacent sheets.
- Or, loose-laid **Mapeplan M 18** 1.8 mm-thick, UV-resistant and weather-resistant synthetic membrane in PVC-P, reinforced with high-strength polyester mat (see section [N.8.1.2](#)), with overlaps approximately 12 cm wide between adjacent sheets.

The membrane is then spot-fixed in place with mechanical fasteners applied under the overlaps to counteract the suction effect of wind.

Heat-weld the overlaps with a manual and automatic hot-air welder after cleaning them with Mapeplan Cleaner.

Carry out manual heat-welding by spot-welding, internal pre-welding and final external welding to form a weathertight seal.

Flexible polyolefin (TPO/FPO) membranes

- Loose-laid **Mapeplan T M 15** 1.5 mm-thick, UV-resistant and weather-resistant synthetic waterproof membrane in flexible polyolefin (TPO/FPO) reinforced with high-strength polyester mat (see section [N.8.1.3](#)), with overlaps approximately 12 cm wide between adjacent sheets.
- Or, loose-laid **Mapeplan T M 18** 1.8 mm-thick, UV-resistant and weather-resistant synthetic waterproof membrane in flexible polyolefin (TPO/FPO) reinforced with high-strength polyester mat (see section [N.8.1.4](#)), with overlaps approximately 12 cm wide between adjacent sheets.

The membrane is then spot-fixed in place with mechanical fasteners applied under the overlaps to counteract the suction effect of wind.

Heat-weld the overlaps with a manual and automatic hot-air welder after cleaning them with Mapeplan T Cleaner.

Carry out manual heat-welding by spot-welding, internal pre-welding and final external welding to form a weathertight seal.

Vertical turn-ups

PVC-P membranes

Vertical turn-ups for waterproof membranes around the edges of roofs, wall fillets, mass fillets, skylights, etc. using:

- **Mapeplan B 15** 1.5 mm-thick, UV-resistant and weather-resistant membrane in PVC-P reinforced with dimensionally-stable glass mat (see section **N.2.1.6**) for 1.5 mm thick waterproof membranes;
- **Mapeplan B 18** 1.8 mm-thick, UV-resistant and weather-resistant membrane in PVC-P reinforced with dimensionally-stable glass mat (see section **N.2.1.7**) for 1.8 mm thick waterproof membranes.

Fully-bond the turn-ups to the substrate using **Mapeplan ADS 200**, a specific contact adhesive.

Heat-weld the turn-ups to the membrane with a manual and/or automatic hot-air welder after cleaning them with Mapeplan Cleaner.

Carry out manual heat-welding by spot-welding, internal pre-welding and final external welding to form a weathertight seal.

Flexible polyolefin (TPO/FPO) membranes

Vertical turn-ups for waterproof membranes around the edges of roofs, wall fillets, mass fillets, skylights, etc. using:

- **Mapeplan T B 15** 1.5 mm-thick, UV-resistant and weather-resistant membrane in flexible polyolefin (TPO/FPO) reinforced with dimensionally-stable glass mat, with a high-reflectance, Smart White surface (see section **N.2.1.8**) for 1.5 mm thick waterproof membranes;
- **Mapeplan T B 18** 1.8 mm-thick, UV-resistant and weather-resistant membrane in flexible Polyolefin (TPO/FPO) reinforced with dimensionally-stable glass mat, with a high-reflectance, Smart White surface (see section **N.2.1.9**) for 1.8 mm thick waterproof membranes.

Fully-bond the turn-ups to the substrate using **Mapeplan ADS 300**, a specific contact adhesive.

Heat-weld the turn-ups to the membrane with a manual and automatic hot-air welder after cleaning them with Mapeplan T Cleaner.

Carry out manual heat-welding by spot-welding, internal pre-welding and final external welding to form a weathertight seal.

Mechanical fixing system

Mechanical spot-fixing system applied under the overlaps of the Mapeplan waterproof membrane on concrete substrates (see section ***N.8.1.5***).

The spot-fixing system applied under the overlaps comprises:

- Aluzinc-plated, carbon steel anchoring plates suitable for use with waterproof membranes. The plates have a recess for the heads of the fasteners, are treated with a suitable anti-corrosion product and measure 82x40x1 mm;
- fasteners suitable for the type of substrate and the anchoring plates, such as concrete screws, expansion plugs or special concrete nails, treated with a product to prevent corrosion.

A linear fixing system is applied around the perimeter of the roof, skylights, chimney stacks, wall fillets, etc., and comprises:

- zinc-plated, carbon steel profiled fastening bars, such as Mapeplan Metalbar, with pre-punched 10x8 mm oval holes every 5 cm and the following dimensions: thickness 2 mm; width 33 mm; height 65 mm. The profiled bars must be mechanically strong and have a rounded profile compatible with the waterproof membrane;
- fasteners suitable for the type of substrate around the perimeter of the roof, treated with a product to prevent corrosion;
- 4 mm-diameter, anti-tear seaming cord applied around the Mapeplan Metalbar profiles by hot-air welding to the Mapeplan waterproof membrane.

To guarantee a good hold for the fixing system, the anchorage substrate must have the following minimum requirements:

compressive strength: $\geq 25 \text{ N/mm}^2$

minimum thickness: 50 mm.

If in doubt, we recommend carrying out preliminary pull-out tests directly on site.

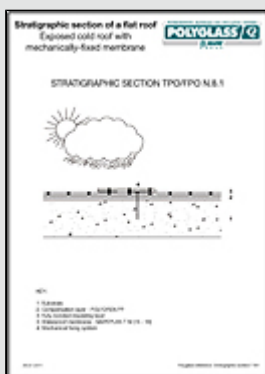

N.8 MECHANICALLY-FIXED WATERPROOFING SYSTEMS FOR EXPOSED FLAT ROOFS

N.8.1.1 Application of 1.5 mm-thick synthetic waterproof membrane in PVC-P

Supply and application of UV-resistant and weather-resistant synthetic waterproof membrane in PVC-P reinforced with high-strength polyester mat (such as **Mapeplan M 15** produced by POLYGLASS S.p.A.). The material must be produced by “multi-extrusion coating”, a single-step production process which allows the internal reinforcement to be inserted without pre-lamination, and must have a product certificate and marked with the CE symbol in compliance with EN 13956 standards.

The effective thickness must be at least 1.5 mm (-5/+10%) according to EN 1849-2 standards.

The material must have the following characteristics:

visible defects according to EN 1850-2:	none
straightness according to EN 1848-2:	≤ 30 mm
flatness according to EN 1848-2:	≤ 10 mm
mass per unit area according to EN 1849-2:	1.8 kg/m ² (-5/+10%)
impermeability to water according to EN 1928:	≥ 400 kPa/72h
reaction to fire according to EN 13501-1:	Euroclass E
resistance to hail according to EN 13583:	rigid substrates: ≥ 20 m/s
resistance to hail according to EN 13583:	soft substrates: ≥ 30 m/s
peel strength of welds according to EN 12316-2:	≥ 300 N/50 mm
shear strength of welds according to EN 12317-2:	≥ 650 N/50 mm
vapour diffusion resistance according to EN 1931:	μ 19,000
tensile strength according to EN 12311-2:	≥ 1100 N/50 mm
elongation at failure according to EN 12311-2:	≥ 15%
impact resistance according to EN 12691:	method A ≥ 600 mm
impact resistance according to EN 12691:	method B ≥ 800 mm
static puncture resistance CBR according to EN 12730-B:	≥ 20 kg
tear strength according to EN 12310-2:	≥ 200 N
dimensional stability according to EN 1107-2:	≤ 0.5%
foldability at low temperatures according to EN 495-5:	≤ -25 °C
resistance to UV rays according to EN 1297:	compliant: class 0

production certified according to ISO 9001 and ISO 14001 standards.

The membrane must be specifically formulated for application on fully-exposed flat roofs using mechanical fixing systems.

Loose-lay the membrane, overlap the edges of adjacent sheets by approximately 12 cm and apply mechanical spot-fasteners under the overlaps to counteract the suction effect of wind.

Heat-weld the overlaps using a manual and automatic hot-air welder after cleaning them with a specific cleaning product (such as Mapeplan Cleaner produced by POLYGLASS S.p.A.). Carry out manual heat-welding by spot-welding, internal pre-welding and final external welding to form a weathertight seal.

Included and calculated in the price for work carried out according to specification:

– per square metre

.....(€/m²)

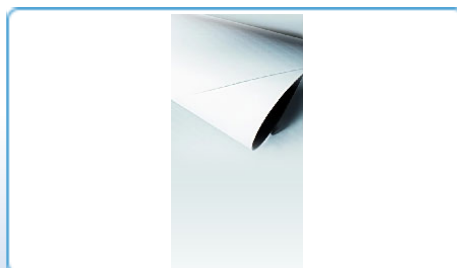

N.8 MECHANICALLY-FIXED WATERPROOFING SYSTEMS FOR EXPOSED FLAT ROOFS

N.8.1.2 Application of 1.8 mm-thick synthetic waterproof membrane in PVC-P

Supply and application of UV-resistant and weather-resistant synthetic waterproof membrane in PVC-P reinforced with high-strength polyester mat (such as **Mapeplan M 18** produced by POLYGLASS S.p.A.). The material must be produced by “multi-extrusion coating”, a single-step production process which allows the internal reinforcement to be inserted without pre-lamination, and must have a product certificate and marked with the CE symbol in compliance with EN 13956 standards.

The effective thickness must be at least 1.8 mm (-5/+10%) according to EN 1849-2 standards.

The material must have the following characteristics:

visible defects according to EN 1850-2:	none
straightness according to EN 1848-2:	≤ 30 mm
flatness according to EN 1848-2:	≤ 10 mm
mass per unit area according to EN 1849-2:	2.2 kg/m ² (-5/+10%)
impermeability to water according to EN 1928:	≥ 400 kPa/72h
reaction to fire according to EN 13501-1:	Euroclass E
resistance to hail according to EN 13583:	rigid substrates: ≥ 20 m/s
resistance to hail according to EN 13583:	soft substrates: ≥ 33 m/s
peel strength of welds according to EN 12316-2:	≥ 300 N/50 mm
shear strength of welds according to EN 12317-2:	≥ 650 N/50 mm
vapour diffusion resistance according to EN 1931:	μ 19,000
tensile strength according to EN 12311-2:	≥ 1100 N/50 mm
elongation at failure according to EN 12311-2:	≥ 15%
impact resistance according to EN 12691:	method A ≥ 700 mm
impact resistance according to EN 12691:	method B ≥ 900 mm
static puncture resistance CBR according to EN 12730-B:	≥ 20 kg
tear strength according to EN 12310-2:	≥ 200 N
dimensional stability according to EN 1107-2:	≤ 0.5%
foldability at low temperatures according to EN 495-5:	≤ -25 °C
resistance to UV rays according to EN 1297:	compliant: class 0

production certified according to ISO 9001 and ISO 14001 standards.

The membrane must be specifically formulated for application on fully-exposed flat roofs using mechanical fixing systems.

Loose-lay the membrane, overlap the edges of adjacent sheets by approximately 12 cm and apply mechanical spot-fasteners under the overlaps to counteract the suction effect of wind.

Heat-weld the overlaps using a manual and automatic hot-air welder after cleaning them with a specific cleaning product (such as Mapeplan Cleaner produced by POLYGLASS S.p.A.).

Carry out manual heat-welding by spot-welding, internal pre-welding and final external welding to form a weathertight seal.

Included and calculated in the price for work carried out according to specification:

– per square metre

.....(€/m²)

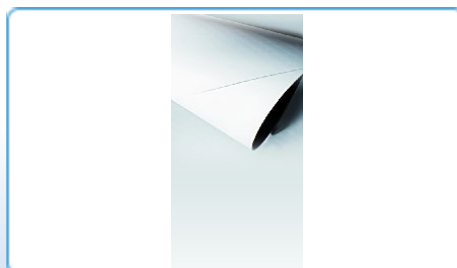

N.8 MECHANICALLY-FIXED WATERPROOFING SYSTEMS FOR EXPOSED FLAT ROOFS

N.8.1.3 Application of 1.5 mm-thick synthetic waterproof membrane in flexible polyolefin (TPO/FPO)

Supply and application of UV-resistant and weather-resistant synthetic waterproof membrane in flexible polyolefin (TPO/FPO) with a high-reflectance Smart White surface, reinforced with high-strength polyester mat (such as **Mapeplan T M** 15 produced by POLYGLASS S.p.A.). The material must be produced by “multi-extrusion coating”, a single-step production process which allows the internal reinforcement to be inserted without pre-lamination, and must have a product certificate and marked with the CE symbol in compliance with EN 13956 standards.

The effective thickness must be at least 1.5 mm (-5/+10%) according to EN 1849-2 standards.

The material must have the following characteristics:

visible defects according to EN 1850-2:	none
straightness according to EN 1848-2:	≤ 30 mm
flatness according to EN 1848-2:	≤ 10 mm
mass per unit area according to EN 1849-2:	1.5 kg/m ² (-5/+10%)
impermeability to water according to EN 1928:	≥ 400 kPa/72h
reaction to fire according to EN 13501-1:	Euroclass E
resistance to hail according to EN 13583:	rigid substrates: ≥ 22 m/s
resistance to hail according to EN 13583:	soft substrates: ≥ 30 m/s
peel strength of welds according to EN 12316-2:	≥ 300 N/50 mm
shear strength of welds according to EN 12317-2:	≥ 650 N/50 mm
vapour diffusion resistance according to EN 1931:	μ 150,000
tensile strength according to EN 12311-2:	≥ 1100 N/50 mm
elongation at failure according to EN 12311-2:	≥ 15%
impact resistance according to EN 12691:	method A ≥ 600 mm
impact resistance according to EN 12691:	method B ≥ 900 mm
static puncture resistance CBR according to EN 12730-B:	≥ 20 kg
tear strength according to EN 12310-2:	≥ 200 N
dimensional stability according to EN 1107-2:	≤ 0.3%
foldability at low temperatures according to EN 495-5:	≤ -35 °C
resistance to UV rays according to EN 1297:	compliant: class 0

production certified according to ISO 9001 and ISO 14001 standards.

The membrane must have a formulation without plasticisers and volatile organic compounds and must have a low impact on the environment and be eco-compatible. Loose-lay the membrane, overlap the edges of adjacent sheets by approximately 12 cm and apply mechanical spot-fasteners under the overlaps to counteract the suction effect of wind. Heat-weld the overlaps using a manual and automatic hot-air welder after cleaning them with a specific cleaning product (such as Mapeplan T Cleaner produced by POLYGLASS S.p.A.). Carry out manual heat-welding by spot-welding, internal pre-welding and final external welding to form a weathertight seal.

Included and calculated in the price for work carried out according to specification:

– per square metre

.....(€/m²)

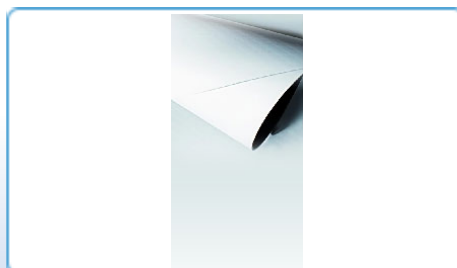

N.8 MECHANICALLY-FIXED WATERPROOFING SYSTEMS FOR EXPOSED FLAT ROOFS

N.8.1.4 Application of 1.8 mm-thick synthetic waterproof membrane in flexible polyolefin (TPO/FPO)

Supply and application of UV-resistant and weather-resistant synthetic waterproof membrane in flexible polyolefin (TPO/FPO) with a high-reflectance Smart White surface, reinforced with high-strength polyester mat (such as **Mapeplan T M** 18 produced by POLYGLASS S.p.A.). The material must be produced by “multi-extrusion coating”, a single-step production process which allows the internal reinforcement to be inserted without pre-lamination, and must have a product certificate and marked with the CE symbol in compliance with EN 13956 standards.

The effective thickness must be at least 1.8 mm (-5/+10%) according to EN 1849-2 standards.

The material must have the following characteristics:

visible defects according to EN 1850-2:	none
straightness according to EN 1848-2:	≤ 30 mm
flatness according to EN 1848-2:	≤ 10 mm
mass per unit area according to EN 1849-2:	1.8 kg/m ² (-5/+10%)
impermeability to water according to EN 1928:	≥ 400 kPa/72h
reaction to fire according to EN 13501-1:	Euroclass E
resistance to hail according to EN 13583:	rigid substrates: ≥ 25 m/s
resistance to hail according to EN 13583: soft substrates	≥ 33 m/s
peel strength of welds according to EN 12316-2:	≥ 300 N/50 mm
shear strength of welds according to EN 12317-2:	≥ 650 N/50 mm
vapour diffusion resistance according to EN 1931:	μ 150,000
tensile strength according to EN 12311-2:	≥ 1100 N/50 mm
elongation at failure according to EN 12311-2:	≥ 15%
impact resistance according to EN 12691:	method A ≥ 800 mm
impact resistance according to EN 12691:	method B ≥ 1000 mm
static puncture resistance CBR according to EN 12730-B:	≥ 20 kg
tear strength according to EN 12310-2:	≥ 200 N
dimensional stability according to EN 1107-2:	≤ 0.3%
foldability at low temperatures according to EN 495-5:	≤ -35 °C
resistance to UV rays according to EN 1297:	compliant: class 0

production certified according to ISO 9001 and ISO 14001 standards.

The membrane must have a formulation without plasticisers and volatile organic compounds and must have a low impact on the environment and be eco-compatible. Loose-lay the membrane, overlap the edges of adjacent sheets by approximately 12 cm and apply mechanical spot-fasteners under the overlaps to counteract the suction effect of wind. Heat-weld the overlaps using a manual and automatic hot-air welder after cleaning them with a specific cleaning product (such as Mapeplan T Cleaner produced by POLYGLASS S.p.A.). Carry out manual heat-welding by spot-welding, internal pre-welding and final external welding to form a weathertight seal.

Included and calculated in the price for work carried out according to specification:

– per square metre

.....(€/m²)

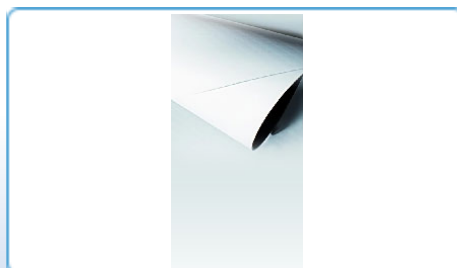

N.8 MECHANICALLY-FIXED WATERPROOFING SYSTEMS FOR EXPOSED FLAT ROOFS

N.8.1.5 Mechanical spot-fixers under the overlaps

Mechanical spot-fixing system for waterproof membranes (such as Mapeplan produced by POLYGLASS S.p.A.) applied under the overlaps comprising:

- Aluzinc-plated, carbon steel anchoring plates suitable for use with waterproof membranes. The plates have a recess for the heads of the fasteners, are treated with a suitable anti-corrosion product and measure 82x40x1 mm.
- Fasteners suitable for the type of substrate and the anchoring plates, such as concrete screws, expansion plugs or special concrete nails, treated with a product to prevent corrosion.
- A linear fixing system is applied around the perimeter of the roof, skylights, chimney stacks, wall fillets, etc., and comprises:
 - zinc-plated, carbon steel profiled fastening bars (such as Mapeplan Metalbar produced by POLYGLASS S.p.A.), with pre-punched 10x8 mm oval holes every 5 cm and the following dimensions: thickness 2 mm; width 33 mm; height 65 mm. The profiled bars must be mechanically strong and have a rounded profile compatible with the waterproof membrane.
 - Fasteners suitable for the type of substrate around the perimeter of the roof, treated with a product to prevent corrosion;
 - 4 mm-diameter, anti-tear seaming cord applied around the profiled bars (such as Mapeplan Metalbar produced by POLYGLASS S.p.A.) by hot-air welding to the waterproof membrane (such as Mapeplan produced by POLYGLASS S.p.A.).

The mechanical fixing system must be supplied by a leading, high-quality manufacturer and be approved/qualified by the manufacturer of the membrane.

The design and dimensions of the mechanical fixing system must be checked and approved by the manufacturer of the membrane prior to execution.

To guarantee a good hold for the fixing system, the anchorage substrate must have the following minimum requirements:

compressive strength	≥ 25 N/mm ²
minimum thickness	50 mm

If in doubt, we recommend carrying out preliminary pull-out tests directly on site.

Included and calculated in the price for work carried out according to specification:

– *per square metre*(€/m²)

N.8 MECHANICALLY-FIXED WATERPROOFING SYSTEMS FOR EXPOSED FLAT ROOFS

N.8.2 MECHANICALLY-FIXED WATERPROOFING SYSTEMS FOR EXPOSED FLAT ROOFS - WARM-ROOF SYSTEM ON A REINFORCED CEMENT SLAB

Procedure

Preparation of the substrate

Installation and/or checking of reinforced concrete or concrete-masonry substrates with a suitable cement levelling layer to form a slope (see section [N.1.1](#)).

When handed over, substrates must be smooth, clean and dry and all corners and edges must be smoothed.

Application of the vapour barrier

After applying a coat of **Polyprimer HP 45** Professional specific primer, supply and application of a vapour barrier by bonding the entire self-adhesive surface of DOUBLE-ADHESIVE bituminous membrane such as **Polyvap SA** 2.0 mm (see section [N.2.2.1](#)), with overlaps approximately 10 cm wide between adjacent sheets. The membrane is made from a special SBS elastomeric compound with internal aluminium foil reinforcement, and the faces of the membrane are protected by a mono-silicon coated polyethylene film to be peeled off when the membrane is applied.

Seal the overlaps between the sheets using a special metal roller.

Application of the insulating layer

- Bonded rigid, self-extinguishing, dimensionally-stable insulating panels made from 150 kPa sintered expanded polystyrene (EPS). Make sure the panels are laid carefully and butted together perfectly to avoid forming thermal bridges (see section [N.7.2.1](#)).
- Or, loose-laid rigid, self-extinguishing, dimensionally-stable insulating panels made from 150 kPa sintered, expanded polystyrene (EPS), slotted together on all four sides and laid carefully to avoid the formation of thermal bridges.

Each panel is then fixed in place using special metal plates and fasteners (screws, plugs, etc.) suitable for the substrate, and treated with a product to prevent corrosion (see section [N.7.2.2](#)).

If in doubt, we recommend carrying out preliminary pull-out tests directly on site.

Application of the separation layer

Loose-laid Polydren PES 200 thermo-calendered, 100% polyester non-woven, needle-punched fabric with a weight of 200 g/m², with overlaps approximately 10 cm wide between adjacent sheets (see section [N.2.2.3](#)). Note: not required with TPO/FPO membranes.

Application of the waterproof membrane

PVC-P membranes

- Loose-laid **Mapeplan M** 15 1.5 mm-thick, UV-resistant and weather-resistant synthetic membrane in PVC-P, reinforced with dimensionally-stable glass mat (see section [N.8.1.1](#)), with overlaps approximately 12 cm wide between adjacent sheets.
- Or, loose-laid **Mapeplan M** 18 1.8 mm-thick, UV-resistant and weather-resistant synthetic membrane in PVC-P, reinforced with dimensionally-stable polyester mat (see section [N.8.1.2](#)), with overlaps approximately 12 cm wide between adjacent sheets.

The membrane is then spot-fixed in place with mechanical fasteners applied under the overlaps to counteract the suction effect of wind.

Heat-weld the overlaps with a manual and automatic hot-air welder after cleaning them with Mapeplan Cleaner.

Carry out manual heat-welding by spot-welding, internal pre-welding and final external welding to form a weathertight seal.

Flexible polyolefin (TPO/FPO) membranes

- Loose-laid **Mapeplan T M 15** 1.5 mm-thick, UV-resistant and weather-resistant synthetic waterproof membrane in flexible polyolefin (TPO/FPO) reinforced with high-strength polyester mat (see section **N.8.1.3**), with overlaps approximately 12 cm wide between adjacent sheets.
- Or, loose-laid **Mapeplan T M 18** 1.8 mm-thick, UV-resistant and weather-resistant synthetic waterproof membrane in flexible polyolefin (TPO/FPO) reinforced with high-strength polyester mat (see section **N.8.1.4**), with overlaps approximately 12 cm wide between adjacent sheets.

The membrane is then spot-fixed in place with mechanical fasteners applied under the overlaps to counteract the suction effect of wind.

Heat-weld the overlaps with a manual and automatic hot-air welder after cleaning them with Mapeplan T Cleaner.

Carry out manual heat-welding by spot-welding, internal pre-welding and final external welding to form a weathertight seal.

Vertical turn-ups

PVC-P membranes

Vertical turn-ups for waterproof membranes around the edges of roofs, wall fillets, mass fillets, skylights, etc. using:

- **Mapeplan B 15** 1.5 mm-thick, UV-resistant and weather-resistant membrane in PVC-P reinforced with dimensionally-stable glass mat (see section **N.2.1.6**) for 1.5 mm thick waterproof membranes;
- **Mapeplan B 18** 1.8 mm-thick, UV-resistant and weather-resistant membrane in PVC-P reinforced with dimensionally-stable glass mat (see section **N.2.1.7**) for 1.8 mm thick waterproof membranes.

Fully-bond the turn-ups to the substrate using **Mapeplan ADS 200**, a specific contact adhesive.

Heat-weld the turn-ups to the membrane with a manual and/or automatic hot-air welder after cleaning them with Mapeplan Cleaner.

Carry out manual heat-welding by spot-welding, internal pre-welding and final external welding to form a weathertight seal.

Flexible polyolefin (TPO/FPO) membranes

Vertical turn-ups for waterproof membranes around the edges of roofs, wall fillets, mass fillets, skylights, etc. using:

- **Mapeplan T B 15** 1.5 mm-thick, UV-resistant and weather-resistant membrane in flexible polyolefin (TPO/FPO) reinforced with dimensionally-stable glass mat, with a high-reflectance, Smart White surface (see section **N.2.1.8**) for 1.5 mm thick waterproof membranes;
- **Mapeplan T B 18** 1.8 mm-thick, UV-resistant and weather-resistant membrane in flexible polyolefin (TPO/FPO) reinforced with dimensionally-stable glass mat, with a high-reflectance, Smart White surface (see section **N.2.1.9**) for 1.8 mm thick waterproof membranes.

Fully-bond the turn-ups to the substrate using **Mapeplan ADS 300**, a specific contact adhesive.

Heat-weld the turn-ups to the membrane with a manual and automatic hot-air welder after cleaning them with Mapeplan T Cleaner.

Carry out manual heat-welding by spot-welding, internal pre-welding and final external welding to form a weathertight seal.

Mechanical fixing system

Mechanical spot-fixing system applied under the overlaps of the Mapeplan waterproof membrane on concrete substrates (see section **N.8.1.5**).

The spot-fixing system applied under the overlaps comprises:

- Aluzinc-plated, carbon steel anchoring plates suitable for use with waterproof membranes. The plates have a recess for the heads of the fasteners, are treated with a suitable anti-corrosion product and measure 82x40x1 mm;
- fasteners suitable for the type of substrate and the anchoring plates, such as concrete screws, expansion plugs or special concrete nails, treated with a product to prevent corrosion.

A linear fixing system is applied around the perimeter of the roof, skylights, chimney stacks, wall fillets, etc., and comprises:

- zinc-plated, carbon steel profiled fastening bars (such as Mapeplan Metalbar produced by POLYGLASS S.p.A.), with pre-punched 10x8 mm oval holes every 5 cm and the following dimensions: thickness 2 mm; width 33 mm; height 65 mm. The profiled bars must be mechanically strong and have a rounded profile compatible with the waterproof membrane;
- fasteners suitable for the type of substrate around the perimeter of the roof, treated with a product to prevent corrosion;
- 4 mm-diameter, anti-tear seaming cord applied around the Mapeplan Metalbar profiles by hot-air welding to the Mapeplan waterproof membrane.

To guarantee a good hold for the fixing system, the anchorage substrate must have the following minimum requirements:

compressive strength: $\geq 25 \text{ N/mm}^2$
 minimum thickness: 50 mm.

If in doubt, we recommend carrying out preliminary pull-out tests directly on site.



N.8 MECHANICALLY-FIXED WATERPROOFING SYSTEMS FOR EXPOSED FLAT ROOFS

N.8.3 MECHANICALLY-FIXED WATERPROOFING SYSTEMS FOR EXPOSED FLAT ROOFS - WARM-ROOF SYSTEM ON CORRUGATED STEEL SHEET Procedure

Preparation of the substrate

Installation and/or checking of corrugated carbon steel sheet flat roof dimensioned to withstand the design loads and overloads (see section [N.1.1](#)).

When handed over, substrates must be smooth, clean and dry and all corners and edges must be smoothed.

Application of the vapour control layer

Loose-laid vapour control/barrier layer in sheets of 0.3 mm thick, transparent, low density LDPE polyethylene (such as Mapeplan VB PE produced by POLYGLASS S.p.A.), with overlaps approximately 10 cm wide between adjacent sheets (see section [N.8.3.1](#)).

Seal the overlaps using single-sided adhesive tape.

Application of the insulating layer

Loose-laid rigid, self-extinguishing, dimensionally-stable insulating panels made from 150 kPa sintered, expanded polystyrene (EPS), slotted together on all four sides and laid carefully to avoid the formation of thermal bridges.

Each panel is then fixed in place using special metal plates and fasteners (screws, plugs, etc.) suitable for the substrate, and treated with a product to prevent corrosion ([N.7.2.2](#)).

If in doubt, we recommend carrying out preliminary pull-out tests directly on site.

Application of the separation layer

Loose-laid Polydren PES 200 thermo-calendered, 100% polyester non-woven, needle-punched fabric with a weight of 200 g/m², with overlaps approximately 10 cm wide between adjacent sheets (see section [N.2.2.3](#)). Note: not required with TPO/FPO membranes.

Application of the waterproof membrane

PVC-P membranes

- Loose-laid **Mapeplan M 15** 1.5 mm-thick, UV-resistant and weather-resistant synthetic membrane in PVC-P, reinforced with dimensionally-stable glass mat (see section [N.8.1.1](#)), with overlaps approximately 12 cm wide between adjacent sheets.
- Or, loose-laid **Mapeplan M 18** 1.8 mm-thick, UV-resistant and weather-resistant synthetic membrane in PVC-P, reinforced with dimensionally-stable polyester mat (see section [N.8.1.2](#)), with overlaps approximately 12 cm wide between adjacent sheets.

The membrane is then spot-fixed in place with mechanical fasteners applied under the overlaps to counteract the suction effect of wind.

Heat-weld the overlaps with a manual and automatic hot-air welder after cleaning them with Mapeplan Cleaner.

Carry out manual heat-welding by spot-welding, internal pre-welding and final external welding to form a weathertight seal.

Flexible polyolefin (TPO/FPO) membranes

- Loose-laid **Mapeplan T M 15** 1.5 mm-thick, UV-resistant and weather-resistant synthetic waterproof membrane in flexible polyolefin (TPO/FPO) reinforced with high-strength polyester mat (see section **N.8.1.3**), with overlaps approximately 12 cm wide between adjacent sheets.
- Or, loose-laid **Mapeplan T M 18** 1.8 mm-thick, UV-resistant and weather-resistant synthetic waterproof membrane in flexible polyolefin TPO/FPO reinforced with high-strength polyester mat (see section **N.8.1.4**), with overlaps approximately 12 cm wide between adjacent sheets.

The membrane is then spot-fixed in place with mechanical fasteners applied under the overlaps to counteract the suction effect of wind.

Heat-weld the overlaps with a manual and automatic hot-air welder after cleaning them with Mapeplan T Cleaner.

Carry out manual heat-welding by spot-welding, internal pre-welding and final external welding to form a weathertight seal.

Vertical turn-ups

PVC-P membranes

Vertical turn-ups for waterproof membranes around the edges of roofs, wall fillets, mass fillets, skylights, etc. using:

- **Mapeplan B 15** 1.5 mm-thick, UV-resistant and weather-resistant membrane in PVC-P reinforced with dimensionally-stable glass mat (see section **N.2.1.6**) for 1.5 mm thick waterproof membranes;
- **Mapeplan B 18** 1.8 mm-thick, UV-resistant and weather-resistant membrane in PVC-P reinforced with dimensionally-stable glass mat (see section **N.2.1.7**) for 1.8 mm thick waterproof membranes.

Fully-bond the turn-ups to the substrate using **Mapeplan ADS 200**, a specific contact adhesive.

Heat-weld the turn-ups to the membrane with a manual and/or automatic hot-air welder after cleaning them with Mapeplan Cleaner.

Carry out manual heat-welding by spot-welding, internal pre-welding and final external welding to form a weathertight seal.

Flexible polyolefin (TPO/FPO) membranes

Vertical turn-ups for waterproof membranes around the edges of roofs, wall fillets, mass fillets, skylights, etc. using:

- **Mapeplan T B 15** 1.5 mm-thick, UV-resistant and weather-resistant membrane in flexible polyolefin (TPO/FPO) reinforced with dimensionally-stable glass mat, with a high-reflectance, Smart White surface (see section **N.2.1.8**) for 1.5 mm thick waterproof membranes;
- **Mapeplan T B 18** 1.8 mm-thick, UV-resistant and weather-resistant membrane in flexible polyolefin (TPO/FPO) reinforced with dimensionally-stable glass mat, with a high-reflectance, Smart White surface (see section **N.2.1.9**) for 1.8 mm thick waterproof membranes.

Fully-bond the turn-ups to the substrate using **Mapeplan ADS 300**, a specific contact adhesive.

Heat-weld the turn-ups to the membrane with a manual and automatic hot-air welder after cleaning them with Mapeplan T Cleaner.

Carry out manual heat-welding by spot-welding, internal pre-welding and final external welding to form a weathertight seal.

Mechanical fixing system

Mechanical spot-fixing system applied under the overlaps of the waterproof membrane (such as Mapeplan produced by POLYGLASS S.p.A.) on corrugated carbon steel sheet substrates and sandwich panels (see section **N.8.3.2**).

The spot-fixing system applied under the overlaps comprises:

- Aluzinc-plated, carbon steel anchoring plates suitable for use with waterproof membranes. The plates have a recess for the heads of the fasteners, are treated with a suitable anti-corrosion product and measure 82x40x1 mm;
- fasteners suitable for the type of substrate and the anchoring plates, such as self-tapping screws or rivets, treated with a product to prevent corrosion.

A linear fixing system is applied around the perimeter of the roof, skylights, chimney stacks, wall fillets, etc., and comprises:

- zinc-plated, carbon steel profiled fastening bars (such as Mapeplan Metalbar produced by POLYGLASS S.p.A.), with pre-punched 10x8 mm oval holes every 5 cm and the following dimensions: thickness 2 mm; width 33 mm; height 65 mm. The profiled bars must be mechanically strong and have a rounded profile compatible with the waterproof membrane.
- fasteners suitable for the type of substrate around the perimeter of the roof, treated with a product to prevent corrosion;
- 4 mm-diameter, anti-tear seaming cord applied around the profiled bars (such as Mapeplan Metalbar produced by POLYGLASS S.p.A.) by hot-air welding to the waterproof membrane (such as Mapeplan produced by POLYGLASS S.p.A.).

To guarantee a good hold for the fixing system, the anchorage substrate must have the following minimum requirements:

- corrugated sheet in carbon steel;
- minimum thickness: 0.7 mm.

If in doubt, we recommend carrying out preliminary pull-out tests directly on site.

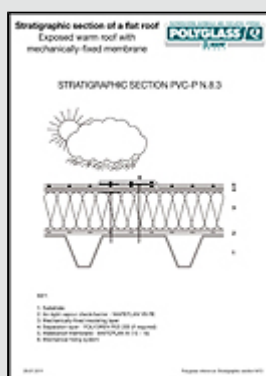

N.8 MECHANICALLY-FIXED WATERPROOFING SYSTEMS FOR EXPOSED FLAT ROOFS**N.8.3.1 Application of the vapour control/barrier layer in sheets of 0.3 mm thick low density LDPE polyethylene**

Supply and application of a vapour control/barrier layer in sheets of 0.3 mm thick, transparent, low density LDPE polyethylene (such as Mapeplan VB PE produced by POLYGLASS S.p.A.). The material must be produced using the blown-film extrusion process, and must not contain adhesive or resin.

The product must have the following characteristics:

average nominal thickness according to EN 1849-2:	0.30 mm ($\pm 5\%$)
resistance to the passage of vapour according to EN 1931:	μ factor 250,000 ($\pm 10,000$)
mass per unit area according to EN 1849-2:	0.280 kg/m ² ($\pm 10\%$)

Loose-lay the material and overlap the edges of adjacent sheets by approximately 10 cm. Seal the overlaps using single-sided adhesive tape.

Included and calculated in the price for work carried out according to specification:

– per square metre(€/m²)

N.8 MECHANICALLY-FIXED WATERPROOFING SYSTEMS FOR EXPOSED FLAT ROOFS

N.8.3.2 Mechanical spot-fixers for corrugated sheet and sandwich panels

Mechanical spot-fixing system applied under the overlaps of the waterproof membrane (such as Mapeplan produced by POLYGLASS S.p.A.) on corrugated sheet and sandwich panel substrates.

The spot-fixing system applied under the overlaps comprises:

- Aluzinc-plated, carbon steel anchoring plates suitable for use with waterproof membranes. The plates have a recess for the heads of the fasteners, are treated with a suitable anti-corrosion product and measure 82x40x1 mm.
- fasteners suitable for the type of substrate and the anchoring plates, such as self-tapping screws or rivets, treated with a product to prevent corrosion.

A linear fixing system is applied around the perimeter of the roof, skylights, chimney stacks, wall fillets, etc., and comprises:

- Zinc-plated, carbon steel profiled fastening bars (such as Mapeplan Metalbar produced by POLYGLASS S.p.A.), with pre-punched 10x8 mm oval holes every 5 cm and the following dimensions: thickness 2 mm; width 33 mm; height 65 mm.

The profiled bars must be mechanically strong and have a rounded profile compatible with the waterproof membrane.

- Fasteners suitable for the type of substrate around the perimeter of the roof, treated with a product to prevent corrosion;
- 4 mm-diameter, anti-tear seaming cord applied around the profiled bars (such as Mapeplan Metalbar produced by POLYGLASS S.p.A.) by hot-air welding to the waterproof membrane (such as Mapeplan produced by POLYGLASS S.p.A.).

The mechanical fixing system must be supplied by a leading, high-quality manufacturer and be approved/qualified by the manufacturer of the membrane.

The design and dimensions of the mechanical fixing system must be checked and approved by the manufacturer of the membrane prior to execution.

To guarantee a good hold for the fixing system, the anchorage substrate must have the following minimum requirements:

- corrugated sheet in carbon steel;
- minimum thickness: 0.7 mm.

If in doubt, we recommend carrying out preliminary pull-out tests directly on site.

Included and calculated in the price for work carried out according to specification:

– *per square metre*(€/m²)

N.8 MECHANICALLY-FIXED WATERPROOFING SYSTEMS FOR EXPOSED FLAT ROOFS

N.8.4 MECHANICALLY-FIXED WATERPROOFING SYSTEMS FOR EXPOSED FLAT ROOFS - WARM-ROOF SYSTEM ON WOODEN FLOOR BOARDS Procedure

Preparation of the substrate

Installation and/or checking of wooden plank roofing dimensioned to withstand the design loads and overloads (see section [N.1.1](#)).

When handed over, substrates must be smooth, clean and dry and all corners and edges must be smoothed.

Application of the vapour control layer

Loose-laid vapour control/barrier layer in sheets of 0.3 mm thick, transparent, low density LDPE polyethylene (such as Mapeplan VB PE 0.30 produced by POLYGLASS S.p.A.), with overlaps approximately 10 cm wide between adjacent sheets (see section [N.8.3.1](#)).

Seal the overlaps using single-sided adhesive tape.

Application of the insulating layer

Loose-laid rigid, self-extinguishing, dimensionally-stable insulating panels made from 150 kPa sintered, expanded polystyrene (EPS), slotted together on all four sides and laid carefully to avoid the formation of thermal bridges.

Each panel is then fixed in place using special metal plates and fasteners (screws, plugs, etc.) suitable for the substrate, and treated with a product to prevent corrosion (see section [N.7.2.2](#)).

If in doubt, we recommend carrying out preliminary pull-out tests directly on site.

Application of the separation layer

Loose-laid Polydren PES 200 thermo-calendered, 100% polyester non-woven, needle-punched fabric with a weight of 200 g/m², with overlaps approximately 10 cm wide between adjacent sheets (see section [N.2.2.3](#)). Note: not required with TPO/FPO membranes.

Application of the waterproof membrane

PVC-P membranes

- Loose-laid **Mapeplan M 15** 1.5 mm-thick, UV-resistant and weather-resistant synthetic membrane in PVC-P, reinforced with dimensionally-stable glass mat (see section [N.8.1.1](#)), with overlaps approximately 12 cm wide between adjacent sheets.
- Or, loose-laid **Mapeplan M 18** 1.8 mm-thick, UV-resistant and weather-resistant synthetic membrane in PVC-P, reinforced with dimensionally-stable polyester mat (see section [N.8.1.2](#)), with overlaps approximately 12 cm wide between adjacent sheets.

The membrane is then spot-fixed in place with mechanical fasteners under the overlaps to counteract the suction effect of wind.

Heat-weld the overlaps with a manual and automatic hot-air welder after cleaning them with Mapeplan Cleaner.

Carry out manual heat-welding by spot-welding, internal pre-welding and final external welding to form a weathertight seal.

Flexible polyolefin (TPO/FPO) membranes

- Loose-laid **Mapeplan T M** 15 1.5 mm-thick, UV-resistant and weather-resistant synthetic waterproof membrane in flexible polyolefin (TPO/FPO) reinforced with high-strength polyester mat (see section **N.8.1.3**), with overlaps approximately 12 cm wide between adjacent sheets.
- Or, loose-laid **Mapeplan T M** 18 1.8 mm-thick, UV-resistant and weather-resistant synthetic waterproof membrane in flexible polyolefin TPO/FPO reinforced with high-strength polyester mat (see section **N.8.1.4**), with overlaps approximately 12 cm wide between adjacent sheets.

The membrane is then spot-fixed in place with mechanical fasteners under the overlaps to counteract the suction effect of wind.

Heat-weld the overlaps with a manual and automatic hot-air welder after cleaning them with Mapeplan T Cleaner.

Carry out manual heat-welding by spot-welding, internal pre-welding and final external welding to form a weathertight seal.

Vertical turn-ups

PVC-P membranes

Vertical turn-ups for waterproof membranes around the edges of roofs, wall fillets, mass fillets, skylights, etc. using:

- **Mapeplan B** 15 1.5 mm-thick, UV-resistant and weather-resistant membrane in PVC-P reinforced with dimensionally-stable glass mat (see section **N.2.1.6**) for 1.5 mm thick waterproof membranes;
- **Mapeplan B** 18 1.8 mm-thick, UV-resistant and weather-resistant membrane in PVC-P reinforced with dimensionally-stable glass mat (see section **N.2.1.7**) for 1.8 mm thick waterproof membranes.

Fully-bond the turn-ups to the substrate using **Mapeplan ADS 200**, a specific contact adhesive.

Heat-weld the turn-ups to the membrane with a manual and/or automatic hot-air welder after cleaning them with Mapeplan Cleaner.

Carry out manual heat-welding by spot-welding, internal pre-welding and final external welding to form a weathertight seal.

Flexible polyolefin (TPO/FPO) membranes

Vertical turn-ups for waterproof membranes around the edges of roofs, wall fillets, mass fillets, skylights, etc. using:

- **Mapeplan T B** 15 1.5 mm-thick, UV-resistant and weather-resistant membrane in flexible polyolefin (TPO/FPO) reinforced with dimensionally-stable glass mat, with a high-reflectance, Smart White surface (see section **N.2.1.8**) for 1.5 mm thick waterproof membranes;
- **Mapeplan T B** 18 1.8 mm-thick, UV-resistant and weather-resistant membrane in flexible polyolefin (TPO/FPO) reinforced with dimensionally-stable glass mat, with a high-reflectance, Smart White surface (see section **N.2.1.9**) for 1.8 mm thick waterproof membranes.

Fully-bond the turn-ups to the substrate using **Mapeplan ADS 300**, a specific contact adhesive.

Heat-weld the turn-ups to the membrane with a manual and automatic hot-air welder after cleaning them with Mapeplan T Cleaner.

Carry out manual heat-welding by spot-welding, internal pre-welding and final external welding to form a weathertight seal.

Mechanical fixing system

Mechanical spot-fixing system applied under the overlaps of the waterproof membrane (such as Mapeplan produced by POLYGLASS S.p.A.) on wooden plank substrates (see section **N.8.4.1**).

The spot-fixing system applied under the overlaps comprises:

- Aluzinc-plated, carbon steel anchoring plates suitable for use with waterproof membranes. The plates have a recess for the heads of the fasteners, are treated with a suitable anti-corrosion product and measure 82x40x1 mm;
- fasteners suitable for the type of substrate and the anchoring plates, such as self-tapping wood screws or rivets, treated with a product to prevent corrosion.

A linear fixing system is applied around the perimeter of the roof, skylights, chimney stacks, wall fillets, etc., and comprises:

- zinc-plated, carbon steel profiled fastening bars (such as Mapeplan Metalbar produced by POLYGLASS S.p.A.), with pre-punched 10x8 mm oval holes every 5 cm and the following dimensions: thickness 2 mm; width 33 mm; height 65 mm. The profiled bars must be mechanically strong and have a rounded profile compatible with the waterproof membrane.
- fasteners suitable for the type of substrate around the perimeter of the roof, treated with a product to prevent corrosion;
- 4 mm-diameter, anti-tear seaming cord applied around the profiled bars (such as Mapeplan Metalbar produced by POLYGLASS S.p.A.) by hot-air welding to the waterproof membrane (such as Mapeplan produced by POLYGLASS S.p.A.).

To guarantee a good hold for the fixing system, the anchorage substrate must have the following minimum requirements:

- wooden planks must be homogeneous and compact, minimum thickness 21 mm;
- minimum thickness of plywood planks 18 mm;
- minimum thickness of oriented strand board (OSB) planks 18 mm.

If in doubt, we recommend carrying out preliminary pull-out tests directly on site.

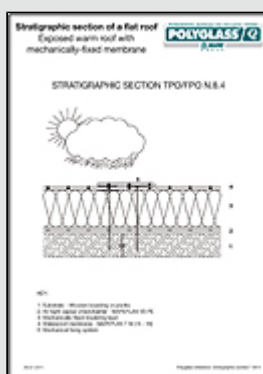

N.8 MECHANICALLY-FIXED WATERPROOFING SYSTEMS FOR EXPOSED FLAT ROOFS

N.8.4.1 Mechanical spot-fixers for wood

Mechanical spot-fixing system applied under the overlaps of the waterproof membrane (such as Mapeplan produced by POLYGLASS S.p.A.) on wooden plank substrates, comprising:

- Aluzinc-plated, carbon steel anchoring plates suitable for use with waterproof membranes. The plates have a recess for the heads of the fasteners, are treated with a suitable anti-corrosion product and measure 82x40x1 mm.
- fasteners suitable for the type of substrate and the anchoring plates, such as self-tapping wood screws or rivets, treated with a product to prevent corrosion.

A linear fixing system is applied around the perimeter of the roof, skylights, chimney stacks, wall fillets, etc., and comprises:

- zinc-plated, carbon steel profiled fastening bars (such as Mapeplan Metalbar produced by POLYGLASS S.p.A.), with pre-punched 10x8 mm oval holes every 5 cm and the following dimensions: thickness 2 mm; width 33 mm; height 65 mm. The profiled bars must be mechanically strong and have a rounded profile compatible with the waterproof membrane.
- Fasteners suitable for the type of substrate around the perimeter of the roof, treated with a product to prevent corrosion;
- 4 mm-diameter, anti-tear seaming cord applied around the profiled bars (such as Mapeplan Metalbar produced by POLYGLASS S.p.A.) by hot-air welding to the waterproof membrane (such as Mapeplan produced by POLYGLASS S.p.A.).

The mechanical fixing system must be supplied by a leading, high-quality manufacturer and be approved/qualified by the manufacturer of the membrane.

The design and dimensions of the mechanical fixing system must be checked and approved by the manufacturer of the membrane prior to execution.

To guarantee a good hold for the fixing system, the anchorage substrate must have the following minimum requirements:

- wooden planks must be homogeneous and compact, minimum thickness 21 mm;
- minimum thickness of plywood planks 18 mm;
- minimum thickness of oriented strand board (OSB) planks 18 mm.

If in doubt, we recommend carrying out preliminary pull-out tests directly on site.

Included and calculated in the price for work carried out according to specification:

- per square metre(€/m²)

**N.9.1 ROOF EDGING
Procedure**

The edging around the roof is made from specific “L” shaped profile:

- zinc-plated steel sheet coated on one side with Mapeplan PVC-P membrane (such as Mapeplan Profilo Perimetrale produced by POLYGLASS S.p.A.) (see section **N.9.1.1**) for PVC-P membranes;
- zinc-plated steel sheet coated on one side with Mapeplan T flexible polyolefin membrane (such as Mapeplan T Profilo Perimetrale produced by POLYGLASS S.p.A.) (see section **N.9.1.2**) for TPO/FPO membranes.

Apply the profile around the edge of the roof using mechanical fasteners (screws, plugs, rivets, etc.) suitable for the type of substrate. Make sure the profiles are aligned correctly when they are applied. Then heat-weld the waterproof membrane/vertical turn-ups to the edging profile.

N.9 STANDARD ACCESSORY PARTS AND DETAILS

N.9.1.1 Roof edging using specific “L” shaped steel sheet profile coated with PVC-P membrane

Supply and application of edging around the roof made from specific “L” shaped profile in zinc-plated steel sheet coated on one side with PVC-P membrane (such as Mapeplan Profilo Perimetrale produced by POLYGLASS S.p.A.).

The material must have the following characteristics:

- thickness: 0.6 mm steel sheet + 1.2 mm membrane (such as Mapeplan produced by POLYGLASS S.p.A.) (PVC-P);
- total flat length: 165 mm;
- height of front face: 50 mm.

Apply the profile around the edge of the roof using mechanical fasteners (screws, plugs, rivets, etc.) suitable for the type of substrate. Make sure the profiles are aligned correctly when they are applied. Then heat-weld the waterproof membrane/vertical turn-ups (such as Mapeplan produced by POLYGLASS S.p.A.) to the edging profile.

Included and calculated in the price for work carried out according to specification:

– *per metre*(€/m)

N.9 STANDARD ACCESSORY PARTS AND DETAILS

N.9.1.2 Roof edging using specific “L” shaped steel sheet profile coated with TPO/FPO membrane

Supply and application of edging around the roof made from specific “L” shaped profile in zinc-plated steel sheet coated on one side with TPO/FPO membrane (such as Mapeplan T Profilo Perimetrale produced by POLYGLASS S.p.A.).

The material must have the following characteristics:

- thickness: 0.6 mm steel sheet + 1.2 mm membrane (such as Mapeplan T produced by POLYGLASS S.p.A.) (TPO/FPO);
- total flat length: 165 mm;
- height of front face: 50 mm.

Apply the profile around the edge of the roof using mechanical fasteners (screws, plugs, rivets, etc.) suitable for the type of substrate. Make sure the profiles are aligned correctly when they are applied. Then heat-weld the waterproof membrane/vertical turn-ups (such as Mapeplan T produced by POLYGLASS S.p.A.) to the edging profile.

Included and calculated in the price for work carried out according to specification:

– *per metre*(€/m)

**N.9.2 WALL FILLETS
Procedure**

Fillets for the walls are made from specific end profiles with a special shape:

- zinc-coated steel sheet coated on one side with Mapeplan PVC-P membrane (such as Mapeplan Profilo Terminale produced by POLYGLASS S.p.A.) (see section **N.9.2.1**) for PVC-P membranes;
- zinc-plated steel sheet coated on one side with Mapeplan T flexible polyolefin (TPO/FPO) membrane (such as Mapeplan T Profilo Terminale produced by POLYGLASS S.p.A.) (see section **N.9.2.2**) for TPO/FPO membranes.

Apply the profile to the walls using mechanical fasteners (screws, plugs, rivets, etc.) suitable for the type of substrate. Make sure the profiles are aligned correctly when they are applied. Then seal the upper part of the profile with suitable sealant, after applying a coat of specific primer if required.

N.9 STANDARD ACCESSORY PARTS AND DETAILS

N.9.2.1 Wall fillets using specific profiles in zinc-plated steel sheet coated with PVC-P membrane

Supply and application of wall fillets made from specific end profiles with a special shape in zinc-plated steel sheet coated on one side with PVC-P membrane (such as Mapeplan Profilo Terminale produced by POLYGLASS S.p.A.).

The material must have the following characteristics:

- thickness: 0.6 mm steel sheet + 1.2 mm membrane (such as Mapeplan produced by POLYGLASS S.p.A.) (PVC-P);
- total flat length: 70 mm;
- upper part specially shaped for bead of sealant.

Apply the profile to the walls using mechanical fasteners (screws, plugs, rivets, etc.) suitable for the type of substrate. Make sure the profiles are aligned correctly when they are applied. Then seal the upper part of the profile with suitable sealant, after applying a coat of specific primer if required.

Included and calculated in the price for work carried out according to specification:

– *per metre*(€/m)

N.9 STANDARD ACCESSORY PARTS AND DETAILS

N.9.2.2 Wall fillets using specific profiles in zinc-plated steel sheet coated with TPO/FPO membrane

Supply and application of wall fillets made from specific end profiles with a special shape in zinc-plated steel sheet coated on one side with TPO/FPO membrane (such as Mapeplan T Profilo Terminale produced by POLYGLASS S.p.A.).

The material must have the following characteristics:

- thickness: 0.6 mm steel sheet + 1.2 mm membrane (such as Mapeplan T produced by POLYGLASS S.p.A.) (TPO/FPO);
- total flat length: 70 mm;
- upper part specially shaped for bead of sealant.

Apply the profile to the walls using mechanical fasteners (screws, plugs, rivets, etc.) suitable for the type of substrate. Make sure the profiles are aligned correctly when they are applied. Then seal the upper part of the profile with suitable sealant, after applying a coat of specific primer if required.

Included and calculated in the price for work carried out according to specification:

– *per metre*(€/m)

N.9.3 DRAINAGE OUTLETS
Procedure

Application of semi-rigid, plastic drainage outlet in:

- PVC-P (such as Mapeplan Bocchetta produced by POLYGLASS S.p.A.) (see section [N.9.3.1](#)) suitable for use with waterproof membranes (such as Mapeplan produced by POLYGLASS S.p.A.), with a double-seal anti-backflow elbow for guttering, for PVC-P membranes;
- TPO/FPO (such as Mapeplan T Bocchetta produced by POLYGLASS S.p.A.) (see section [N.9.3.2](#)) suitable for use with waterproof membranes (such as Mapeplan T produced by POLYGLASS S.p.A.), with a double-seal anti-backflow elbow for guttering, for TPO/FPO membranes.

Heat-weld the outlet to the waterproof membrane and place a round, gravel/leaf guard with special locking fins over the outlet.

N.9 STANDARD ACCESSORY PARTS AND DETAILS

N.9.3.1 Application of a semi-rigid PVC-P drainage outlet and gravel/leaf guard

Supply and application of a semi-rigid, plastic drainage outlet in PVC-P (such as Mapeplan Bocchetta produced by POLYGLASS S.p.A.) suitable for use with waterproof membranes (such as Mapeplan produced by POLYGLASS S.p.A.), with a double-seal anti-backflow elbow for guttering.

The material must have the following characteristics:

- diameter (chosen according to the Mapeplan delivery programme);
- height of fitting: 240 mm.

Heat-weld the outlet to the waterproof membrane (such as Mapeplan produced by POLYGLASS S.p.A.).

Place a round, plastic gravel/leaf guard with special locking fins over the outlet.

Included and calculated in the price for work carried out according to specification:

- *per outlet*(€ each)

N.9 STANDARD ACCESSORY PARTS AND DETAILS**N.9.3.2 Application of a semi-rigid TPO/FPO drainage outlet and gravel/leaf guard**

Supply and application of a semi-rigid, plastic drainage outlet in TPO/FPO (such as Mapeplan T Bocchetta produced by POLYGLASS S.p.A.) suitable for use with waterproof membranes (such as Mapeplan T produced by POLYGLASS S.p.A.), with a double-seal anti-backflow elbow for guttering. The material must have the following characteristics:

- diameter (chosen according to the Mapeplan T delivery programme);
- height of fitting: 240 mm

Heat-weld the outlet to the waterproof membrane (such as Mapeplan T produced by POLYGLASS S.p.A.).

Place a round, plastic gravel/leaf guard with special locking fins over the outlet.

Included and calculated in the price for work carried out according to specification:

- *per outlet*(€ each)

Stratigraphic section of a flat roof

Cold roof ballasted with gravel



STRATIGRAPHIC SECTION PVC-P N.2.1

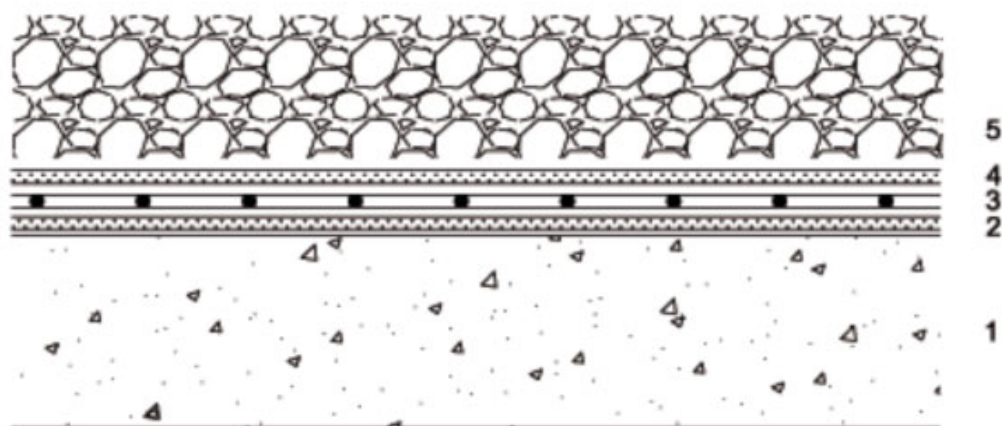

KEY:

1. Substrate
2. Compensation layer - POLYDREN PP
3. Waterproof membrane - MAPEPLAN B (15 - 18)
4. Protection layer - POLYDREN PP
5. Ballast layer - Gravel

Stratigraphic section of a flat roof

Cold roof ballasted with gravel



STRATIGRAPHIC SECTION TPO/FPO N.2.1

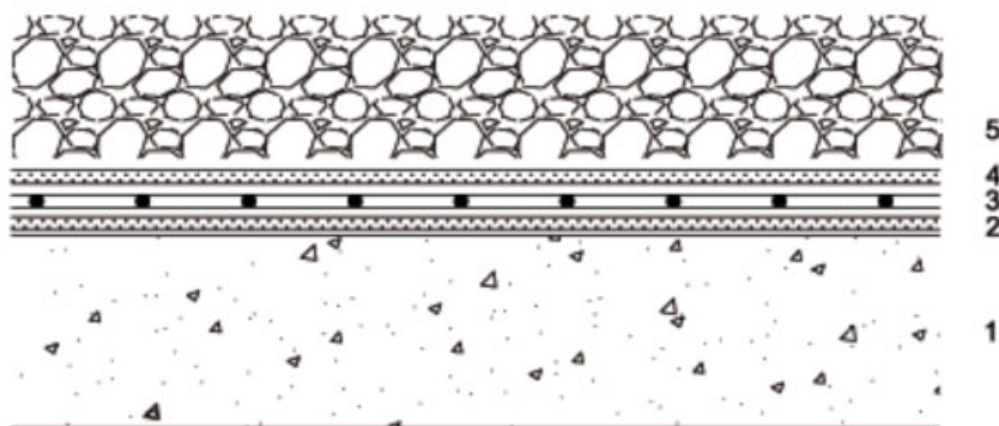

KEY:

1. Substrate
2. Compensation layer - POLYDREN PP
3. Waterproof membrane - MAPEPLAN T B (15 - 18)
4. Protection layer - POLYDREN PP
5. Ballast layer - Gravel

Stratigraphic section of a flat roof

Warm roof ballasted with gravel



STRATIGRAPHIC SECTION PVC-P N.2.2

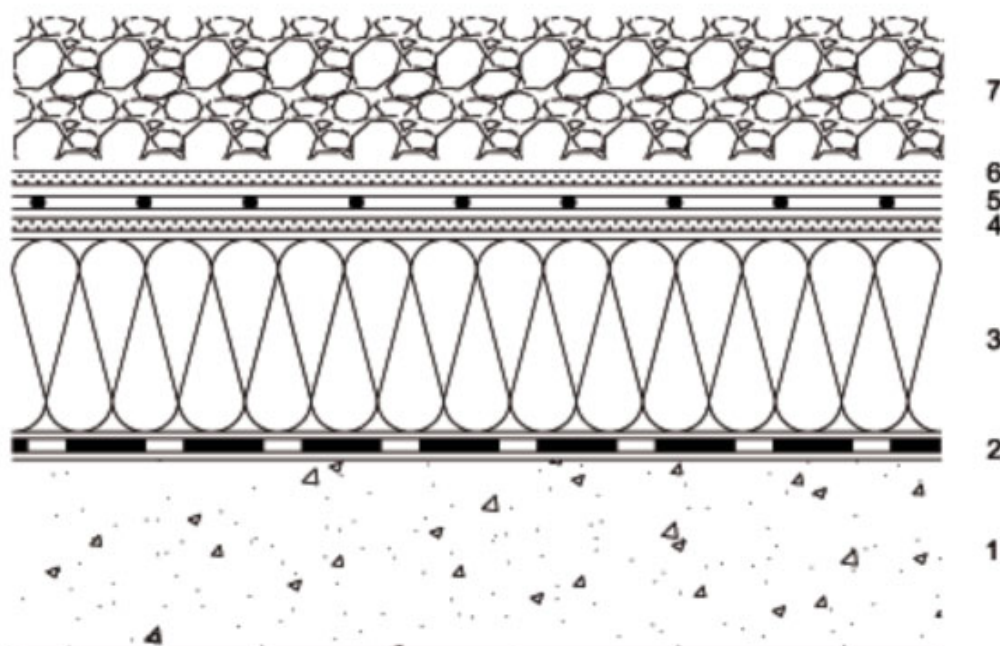

KEY:

1. Substrate
2. Vapour barrier - POLYVAP SA + POLYPRIMER HP 45 PRO primer
3. Insulating layer
4. Separation layer - POLYDREN PES 200 (if required)
5. Waterproof membrane - MAPEPLAN B (15 - 18)
6. Protection layer - POLYDREN PP
7. Ballast layer - Gravel

Stratigraphic section of a flat roof

Warm roof ballasted with gravel



STRATIGRAPHIC SECTION TPO/FPO N.2.2

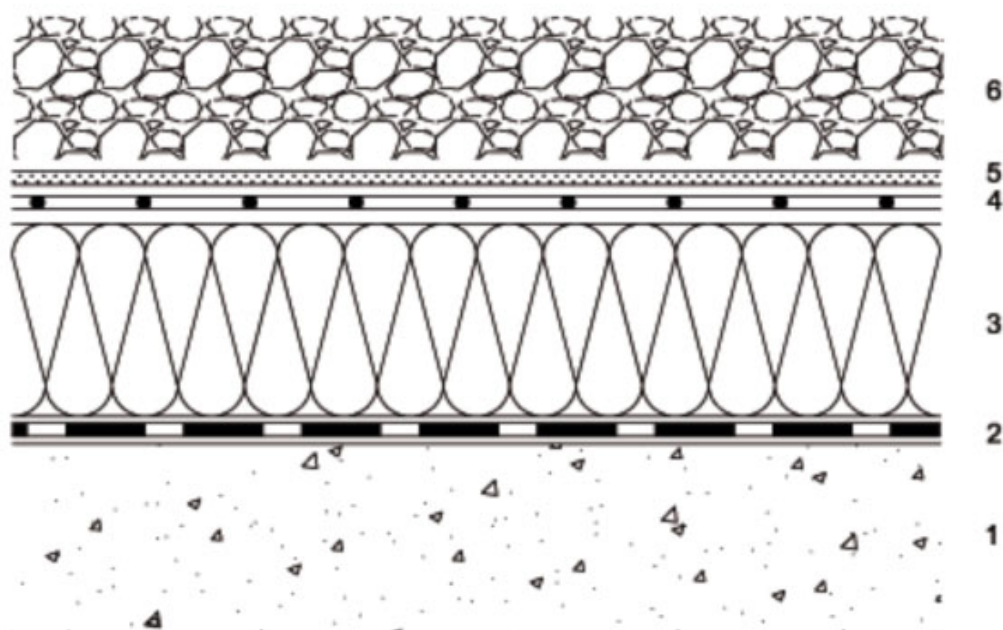

KEY:

1. Substrate
2. Vapour barrier - POLYVAP SA + POLYPRIMER HP 45 PRO primer
3. Insulating layer
4. Waterproof membrane - MAPEPLAN T B (15 - 18)
5. Protection layer - POLYDREN PP
6. Ballast layer - Gravel

Stratigraphic section of a flat roof

Cold roof ballasted
with cement slabs



STRATIGRAPHIC SECTION PVC-P N.3.1

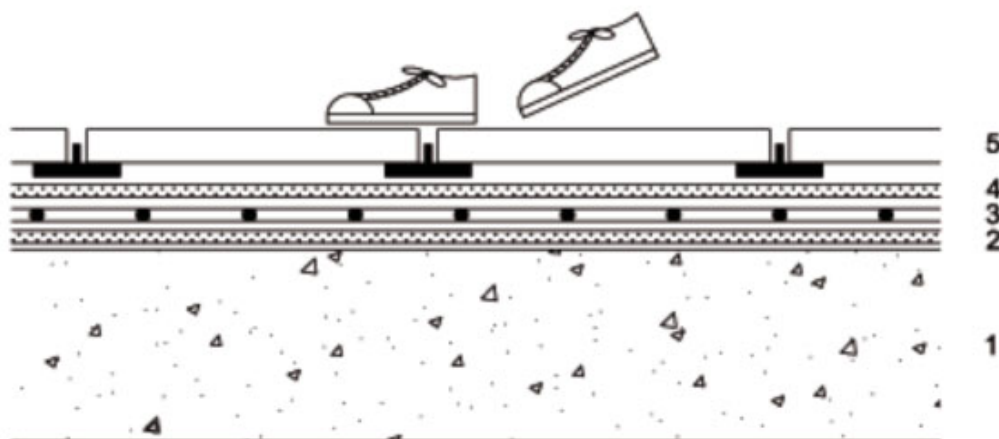

KEY:

1. Substrate
2. Compensation layer - POLYDREN PP
3. Waterproof membrane - MAPEPLAN B (15 - 18)
4. Protection layer - POLYDREN PP
5. Ballast layer - Cement slabs on supports

Stratigraphic section of a flat roof

Cold roof ballasted
with cement slabs



STRATIGRAPHIC SECTION TPO/FPO N.3.1

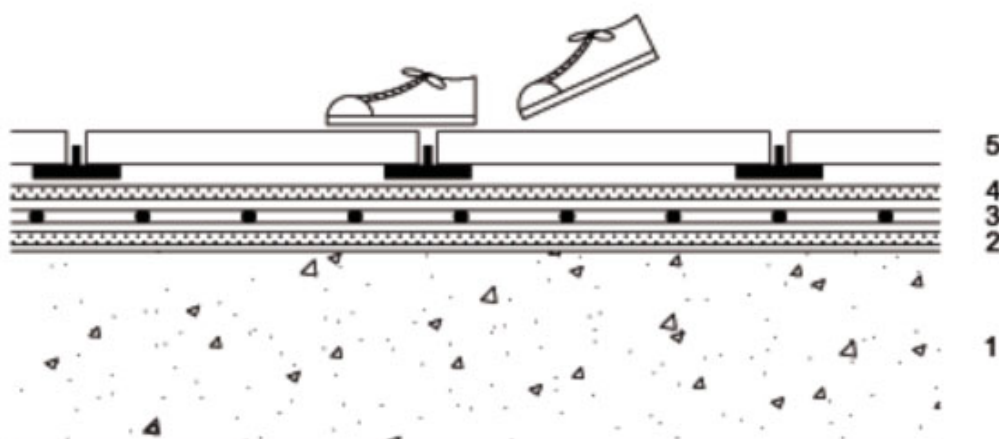

KEY:

1. Substrate
2. Compensation layer - POLYDREN PP
3. Waterproof membrane - MAPEPLAN T B (15 - 18)
4. Protection layer - POLYDREN PP
5. Ballast layer - Cement slabs on supports

Stratigraphic section of a flat roof

Warm roof ballasted
with cement slabs



STRATIGRAPHIC SECTION PVC-P N.3.2

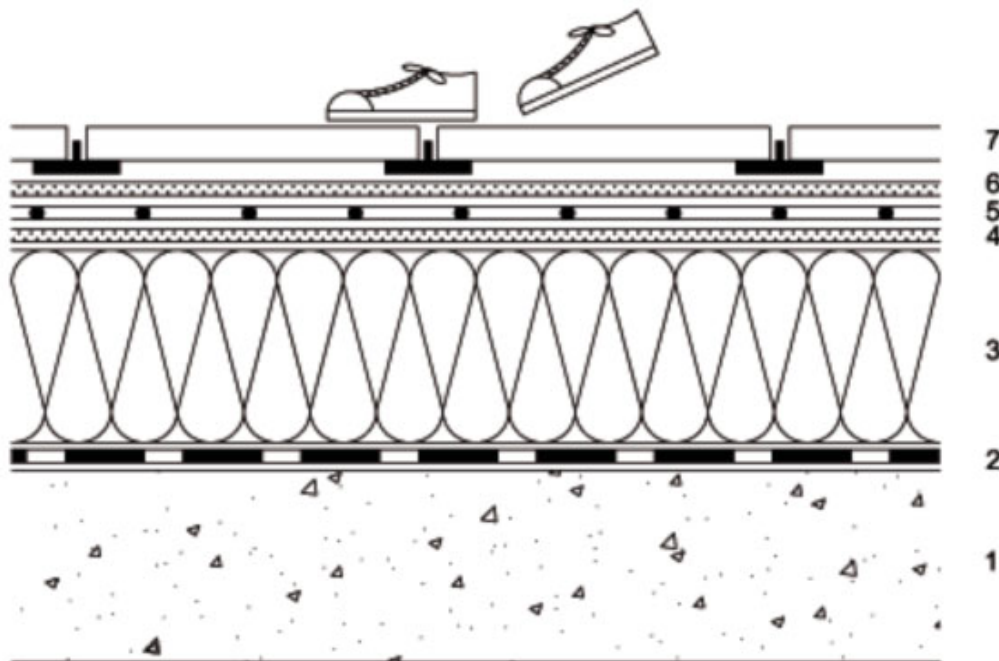

KEY:

1. Substrate
2. Vapour barrier - POLYVAP SA + POLYPRIMER HP 45 PRO primer
3. Insulating layer
4. Separation layer - POLYDREN PES 200 (if required)
5. Waterproof membrane - MAPEPLAN B (15 - 18)
6. Protection layer - POLYDREN PP
7. Ballast layer - Cement slabs on supports

Stratigraphic section of a flat roof

Warm roof ballasted
with cement slabs



STRATIGRAPHIC SECTION TPO/FPO N.3.2

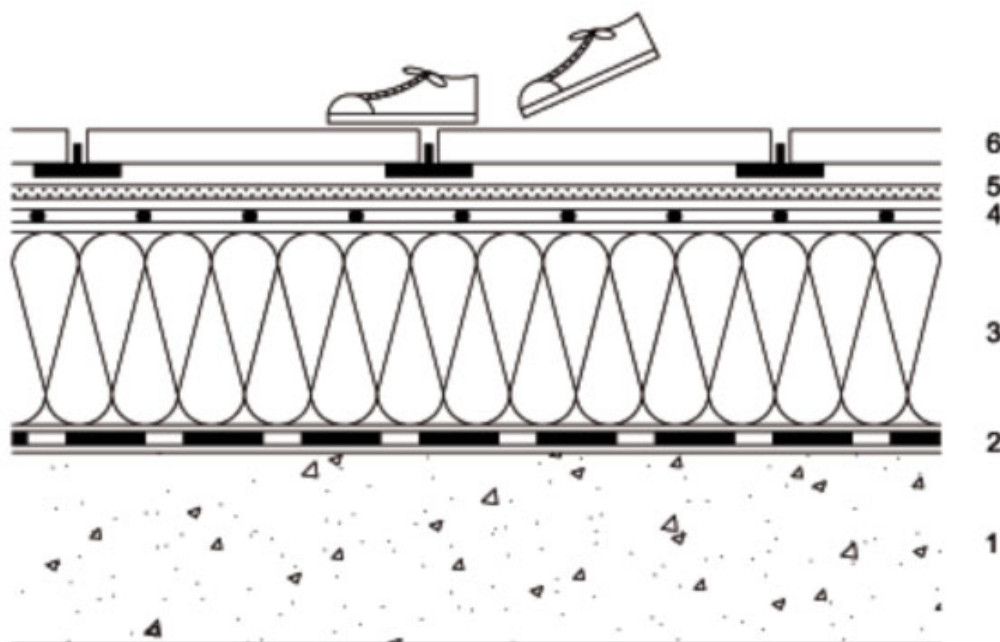

KEY:

1. Substrate
2. Vapour barrier - POLYVAP SA + POLYPRIMER HP 45 PRO primer
3. Insulating layer
4. Waterproof membrane - MAPEPLAN T B (15 - 18)
5. Protection layer - POLYDREN PP
6. Ballast layer - Cement slabs on supports

Stratigraphic section of a flat roof

Cold roof ballasted
with bonded tiles



STRATIGRAPHIC SECTION PVC-P N.4.1

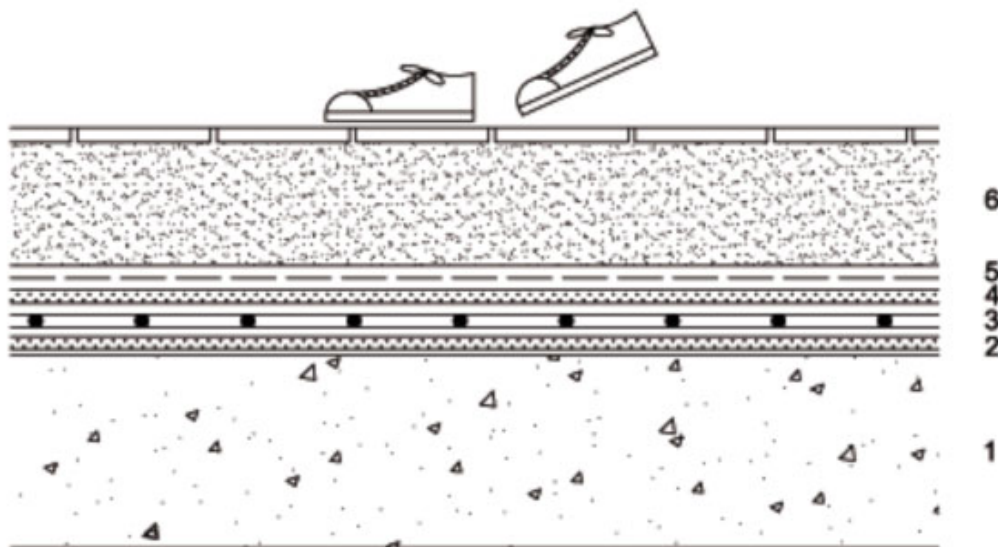

KEY:

1. Substrate
2. Compensation layer - POLYDREN PP
3. Waterproof membrane - MAPEPLAN B (15 - 18)
4. Protection layer - POLYDREN PP
5. Anti-imbibition layer - MAPEPLAN LDPE micro-perforated
6. Pedestrian surface - Bonded tiled flooring

Stratigraphic section of a flat roof

Cold roof ballasted with bonded tiles



STRATIGRAPHIC SECTION TPO/FPO N.4.1

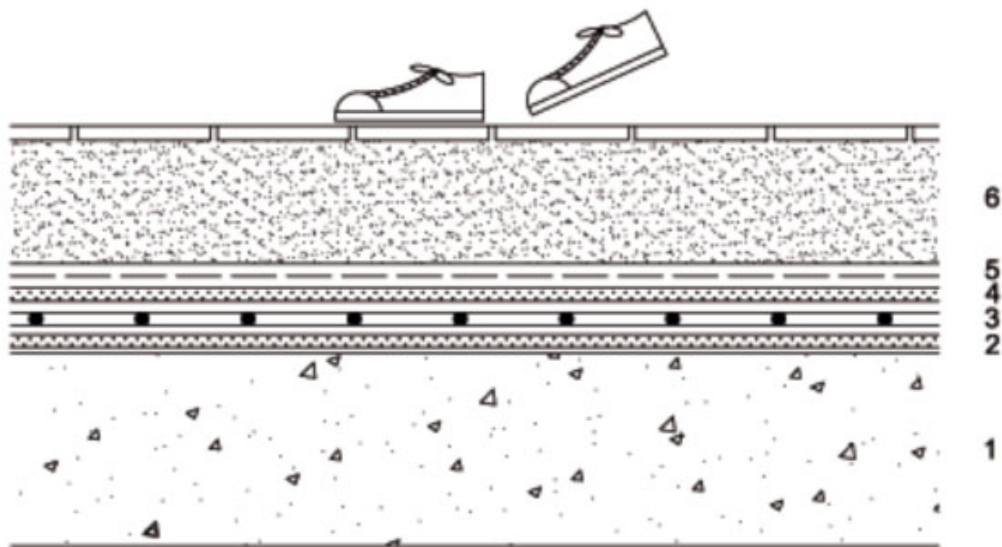

KEY:

1. Substrate
2. Compensation layer - POLYDREN PP
3. Waterproof membrane - MAPEPLAN T B (15 - 18)
4. Protection layer - POLYDREN PP
5. Anti-imbibition layer - MAPEPLAN LDPE micro-perforated
6. Pedestrian surface - Bonded tiled flooring

Stratigraphic section of a flat roof

Warm roof ballasted
with bonded tiles



STRATIGRAPHIC SECTION PVC-P N.4.2

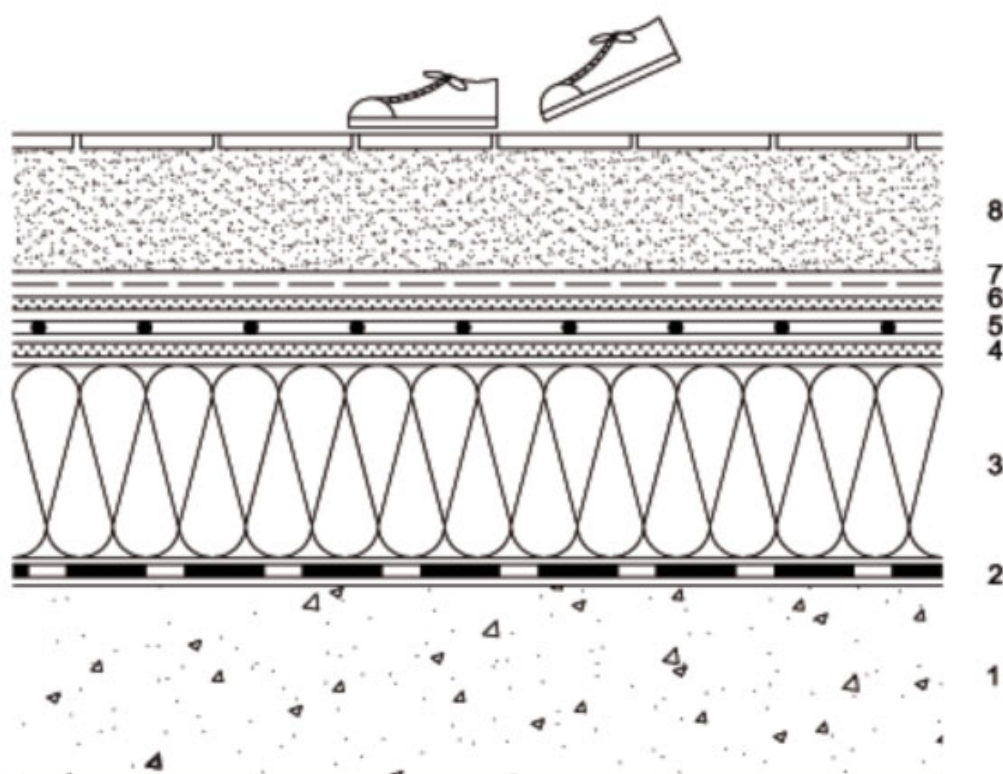

KEY:

1. Substrate
2. Vapour barrier - POLYVAP SA + POLYPRIMER HP 45 PRO primer
3. Insulating layer
4. Separation layer - POLYDREN PES 200 (if required)
5. Waterproof membrane - MAPEPLAN B (15 - 18)
6. Protection layer - POLYDREN PP
7. Anti-imbibition layer - MAPEPLAN LDPE micro-perforated
8. Pedestrian surface - Bonded tiled flooring

Stratigraphic section of a flat roof

Warm roof ballasted with bonded tiles



STRATIGRAPHIC SECTION N.4.2

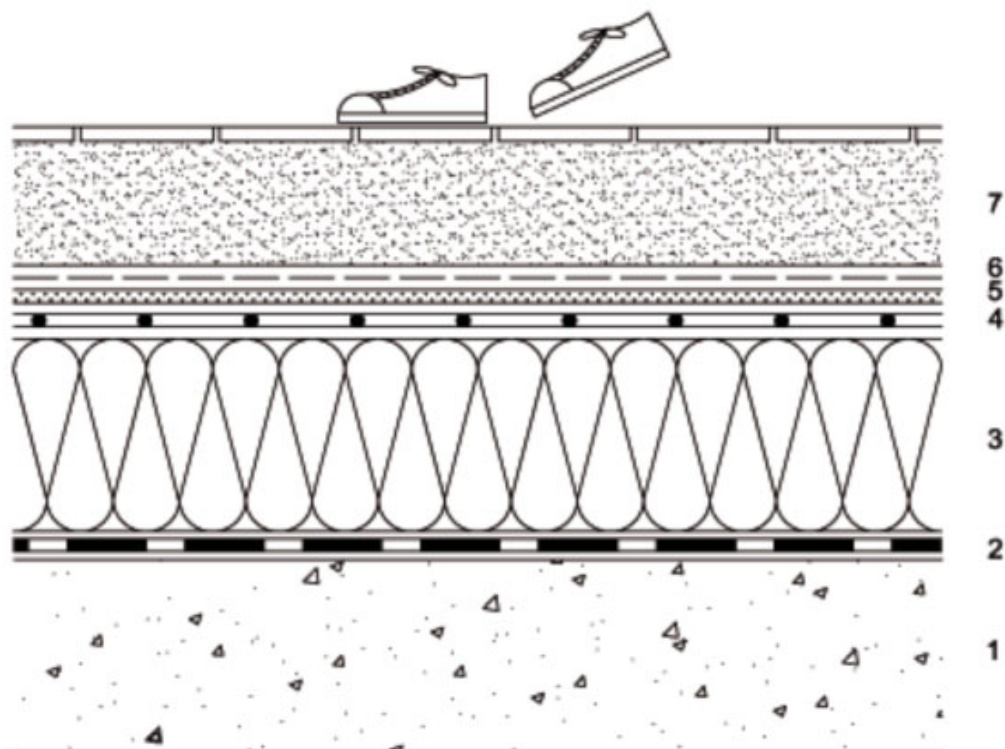

KEY:

1. Substrate
2. Vapour barrier - POLYVAP SA + POLYPRIMER HP 45 PRO primer
3. Insulating layer
4. Waterproof membrane - MAPEPLAN T B (15 - 18)
5. Protection layer - POLYDREN PP
6. Anti-imbibition layer - MAPEPLAN LDPE micro-perforated
7. Pedestrian surface - Bonded tiled flooring

Stratigraphic section of a flat roof

Cold roof ballasted with a concrete screed



STRATIGRAPHIC SECTION PVC-P N.5.1

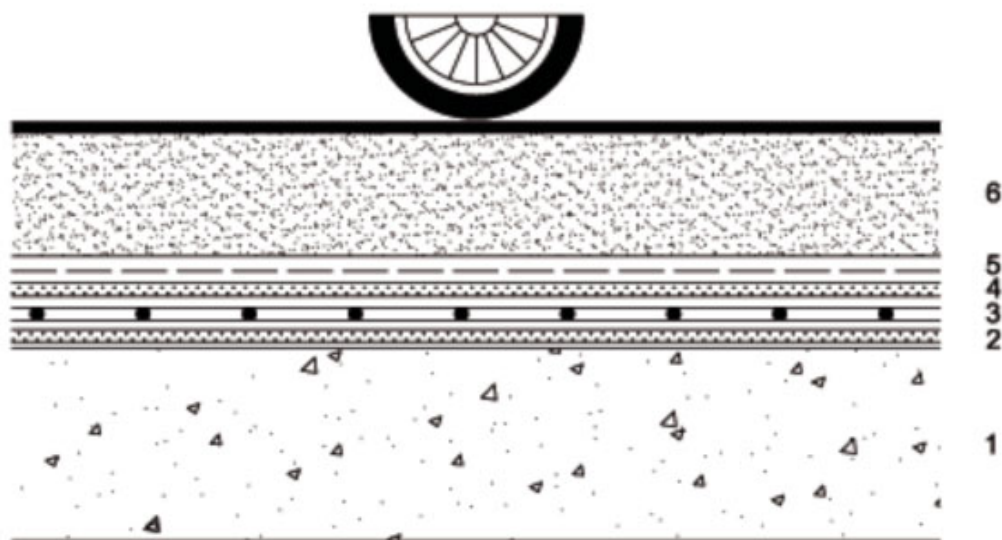

KEY:

1. Substrate
2. Compensation layer - POLYDREN PP
3. Waterproof membrane - MAPEPLAN B (15 - 20)
4. Protection layer - POLYDREN PP
5. Anti-imbibition layer - MAPEPLAN LDPE micro-perforated
6. Vehicular layer - Cementitious screed with wear layer

Stratigraphic section of a flat roof

Cold roof ballasted with
a concrete screed



STRATIGRAPHIC SECTION TPO/FPO N.5.1

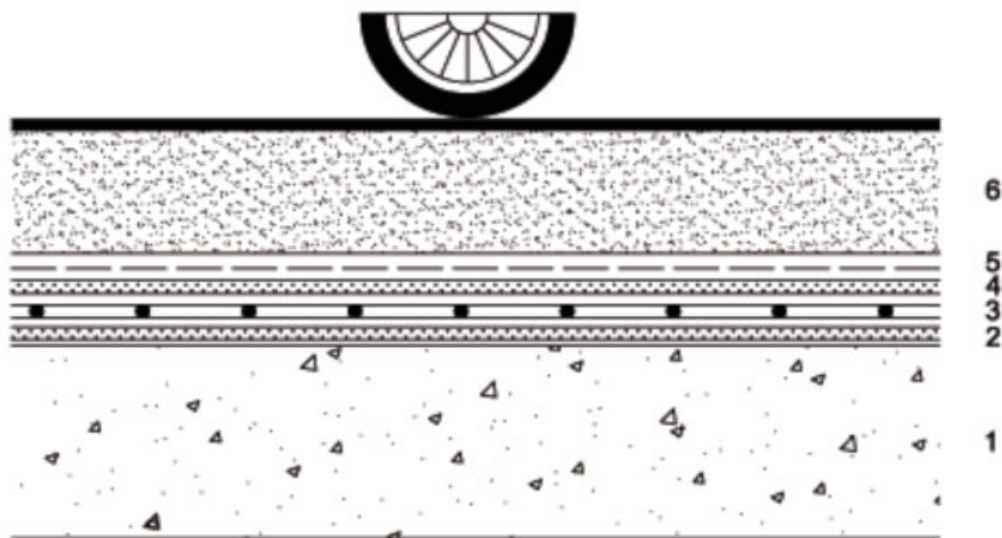

KEY:

1. Substrate
2. Compensation layer - POLYDREN PP
3. Waterproof membrane - MAPEPLAN T B (15 - 20)
4. Protection layer - POLYDREN PP
5. Anti-imbibition layer - MAPEPLAN LDPE micro-perforated
6. Vehicular layer - Cementitious screed with wear layer

Stratigraphic section of a flat roof

Warm roof ballasted with
a concrete screed



STRATIGRAPHIC SECTION PVC-P N.5.2

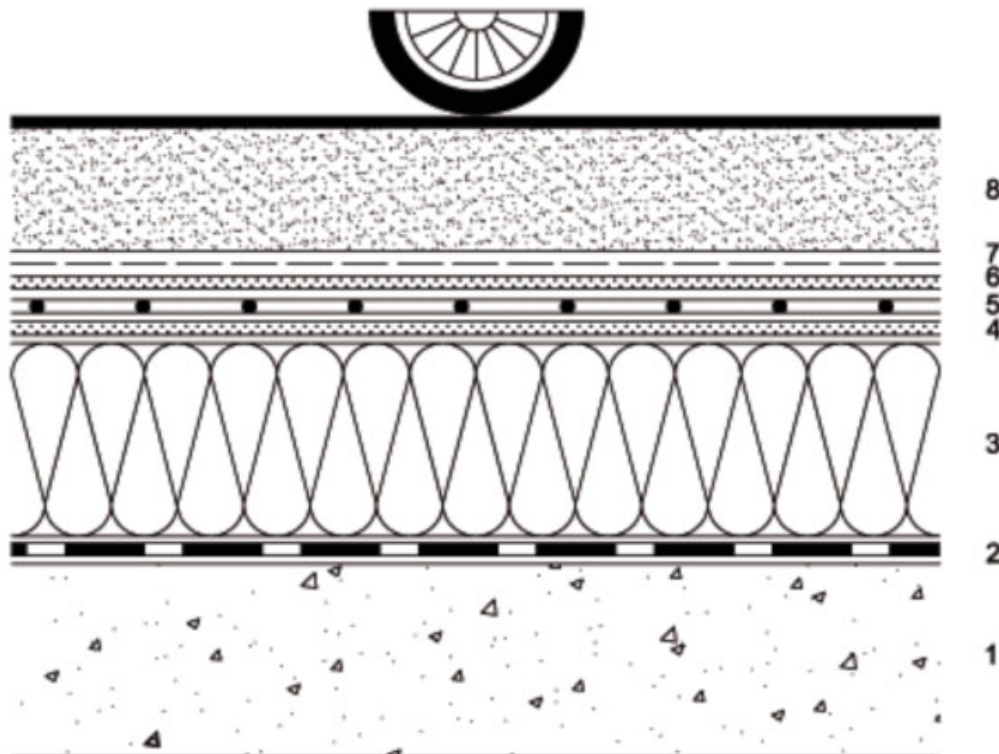

KEY:

1. Substrate
2. Vapour barrier - POLYVAP SA + POLYPRIMER HP 45 PRO primer
3. Insulating layer
4. Separation layer - POLYDREN PES 200 (if required)
5. Waterproof membrane - MAPEPLAN B (15 - 20)
6. Protection layer - POLYDREN PP
7. Anti-imbibition layer - MAPEPLAN LDPE micro-perforated
8. Vehicular layer - Cementitious screed with wear layer

Stratigraphic section of a flat roof

Warm roof ballasted
with a concrete screed



STRATIGRAPHIC SECTION TPO/FPO N.5.2

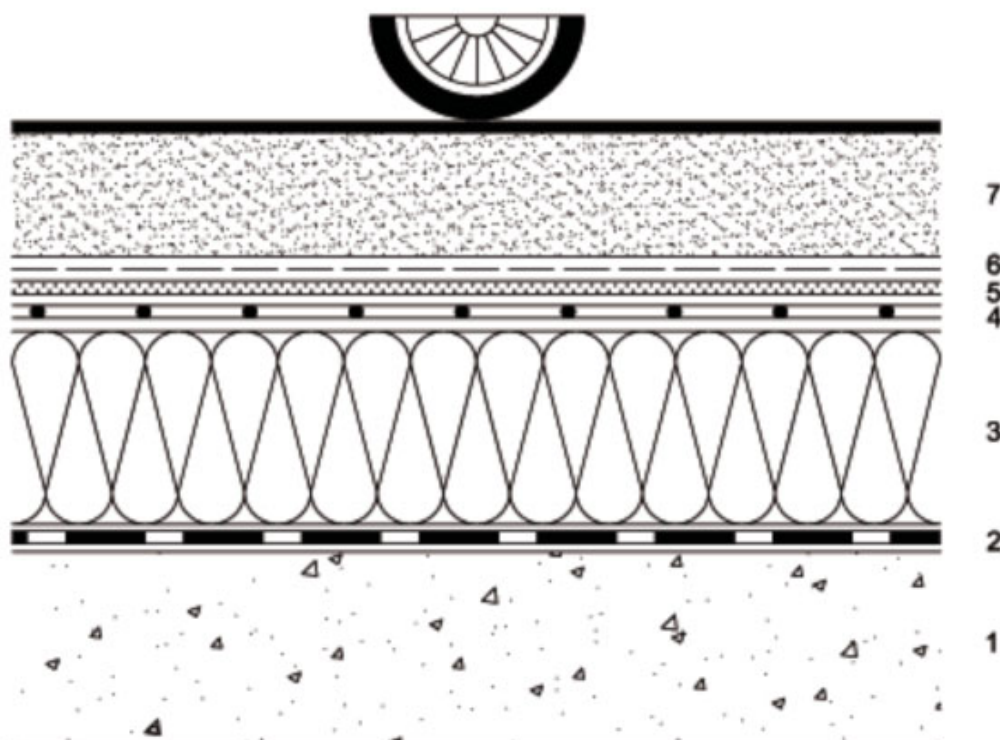

KEY:

1. Substrate
2. Vapour barrier - POLYVAP SA + POLYPRIMER HP 45 PRO primer
3. Insulating layer
4. Waterproof membrane - MAPEPLAN T B (15 - 20)
5. Protection layer - POLYDREN PP
6. Anti-imbibition layer - MAPEPLAN LDPE micro-perforated
7. Vehicular layer - Cementitious screed with wear layer

Stratigraphic section of a flat roof

Cold roof ballasted with garden soil



STRATIGRAPHIC SECTION PVC-P N.6.1

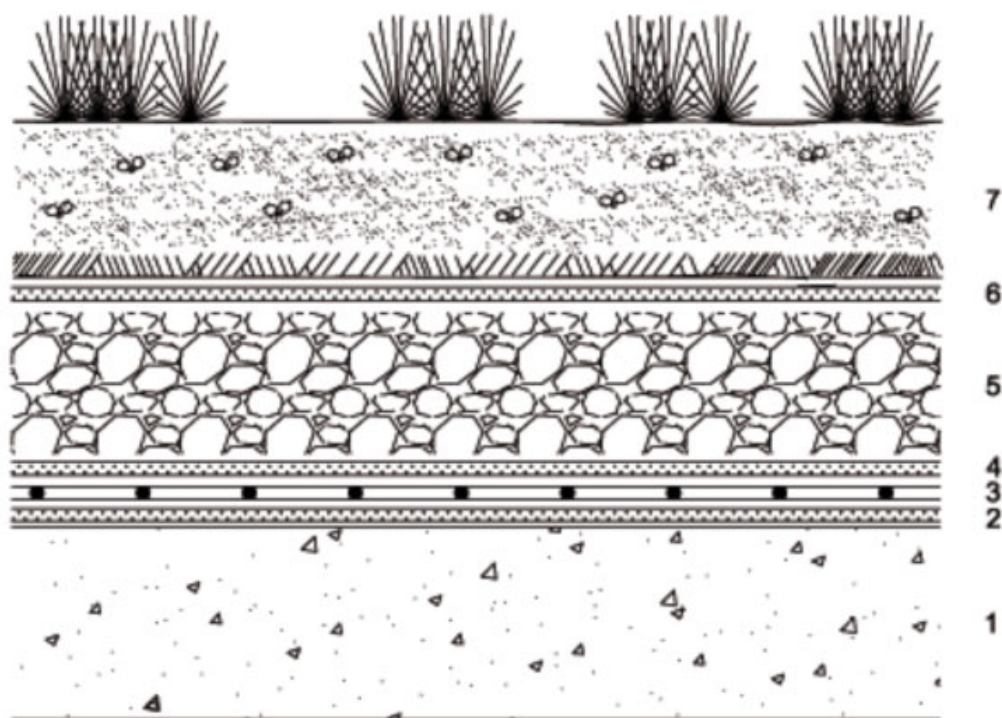

KEY:

1. Substrate
2. Compensation layer - POLYDREN PP
3. Waterproof membrane - MAPEPLAN B (15 - 20)
4. Protection layer - POLYDREN PP
5. Drainage layer
6. Filtration layer - POLYDREN PES 200
7. Garden soil

Stratigraphic section of a flat roof

Cold roof ballasted with garden soil



STRATIGRAPHIC SECTION TPO/FPO N.6.1

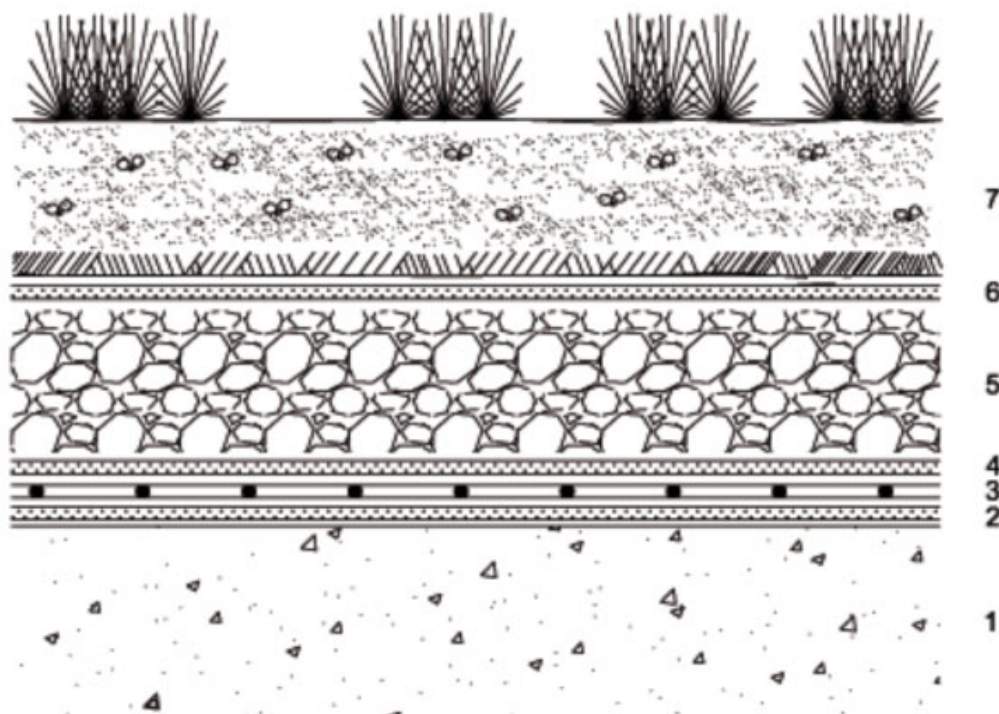

KEY:

1. Substrate
2. Compensation layer - POLYDREN PP
3. Waterproof membrane - MAPEPLAN T B (15 - 20)
4. Protection layer - POLYDREN PP
5. Drainage layer
6. Filtration layer - POLYDREN PES 200
7. Garden soil

29.07.2011

Polyglass reference: Stratigraphic section T B5

Stratigraphic section of a flat roof

Warm roof ballasted with garden soil



STRATIGRAPHIC SECTION PVC-P N.6.2

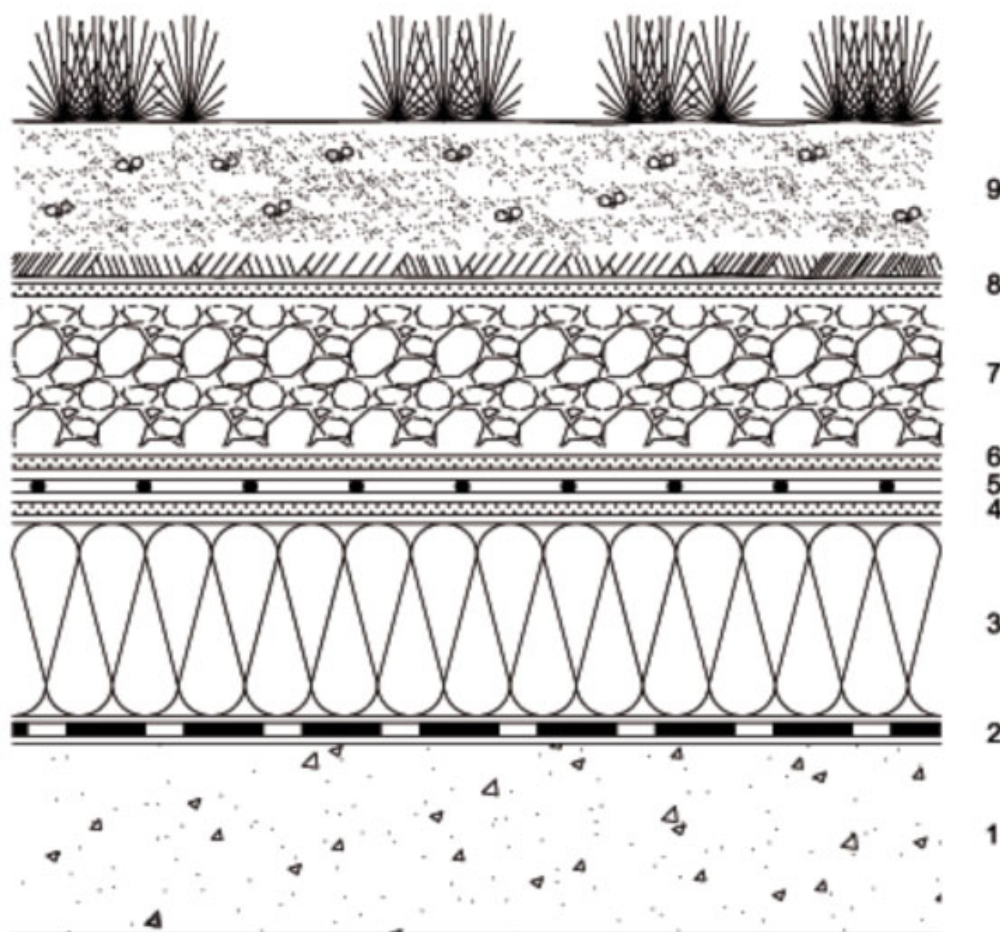

KEY:

1. Substrate
2. Vapour barrier - POLYVAP SA + POLYPRIMER HP 45 PRO primer
3. Insulating layer
4. Separation layer - POLYDREN PES 200 (if required)
5. Waterproof membrane - MAPEPLAN B (15 - 20)
6. Protection layer - POLYDREN PP
7. Drainage layer
8. Filtration layer - POLYDREN PES 200
9. Garden soil

29.07.2011

Polyglass reference: Stratigraphic section B51

Stratigraphic section of a flat roof

Warm roof ballasted with garden soil



STRATIGRAPHIC SECTION TPO/FPO N.6.2

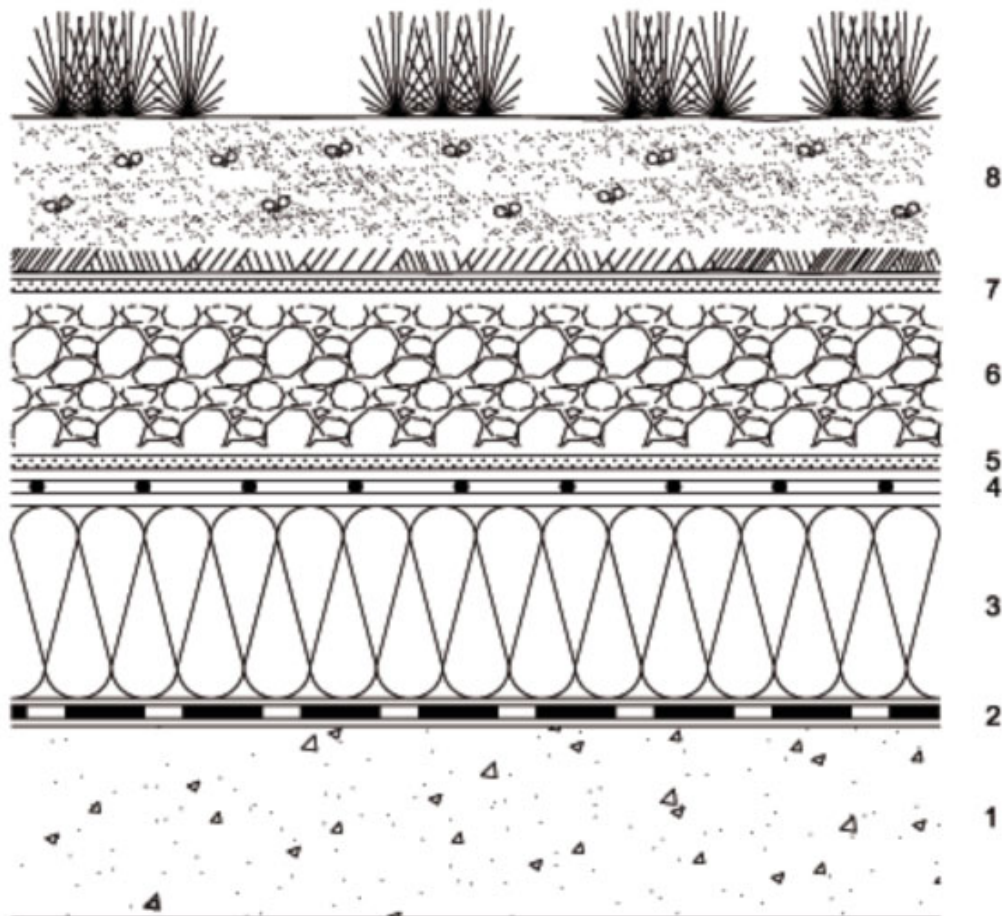

KEY:

1. Substrate
2. Vapour barrier - POLYVAP SA + POLYPRIMER HP 45 PRO primer
3. Insulating layer
4. Waterproof membrane - MAPEPLAN T B (15 - 20)
5. Protection layer - POLYDREN PP
6. Drainage layer
7. Filtration layer - POLYDREN PES 200
8. Garden soil

Stratigraphic section of a flat roof

Exposed cold roof with adhered membrane



STRATIGRAPHIC SECTION PVC-P N.7.1

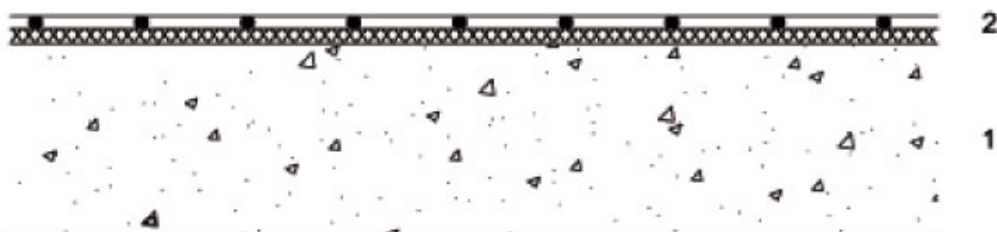
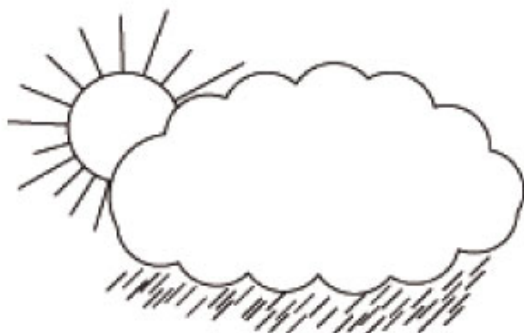

KEY:

1. Substrate
2. Waterproof membrane - MAPEPLAN Af (15 - 18)
fully-bonded with MAPEPLAN ADS 100 adhesive

Stratigraphic section of a flat roof

Exposed cold roof with adhered membrane



STRATIGRAPHIC SECTION TPO/FPO N.7.1

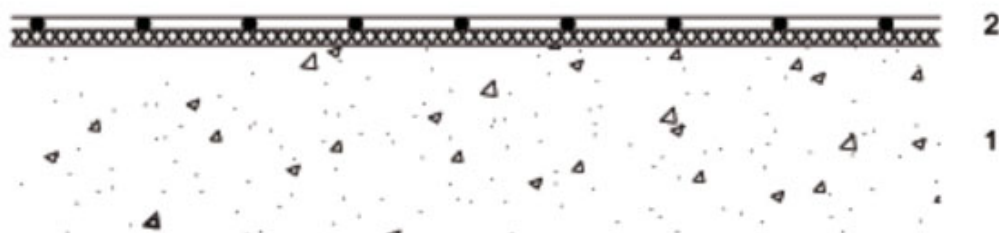
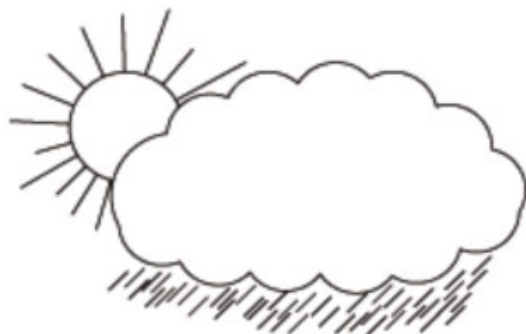

KEY:

1. Substrate
2. Waterproof membrane - MAPEPLAN T Af (15 - 18)
fully-bonded with MAPEPLAN ADS 100 adhesive

Stratigraphic section of a flat roof

Exposed warm roof with adhered membrane



STRATIGRAPHIC SECTION PVC-P N.7.2.A

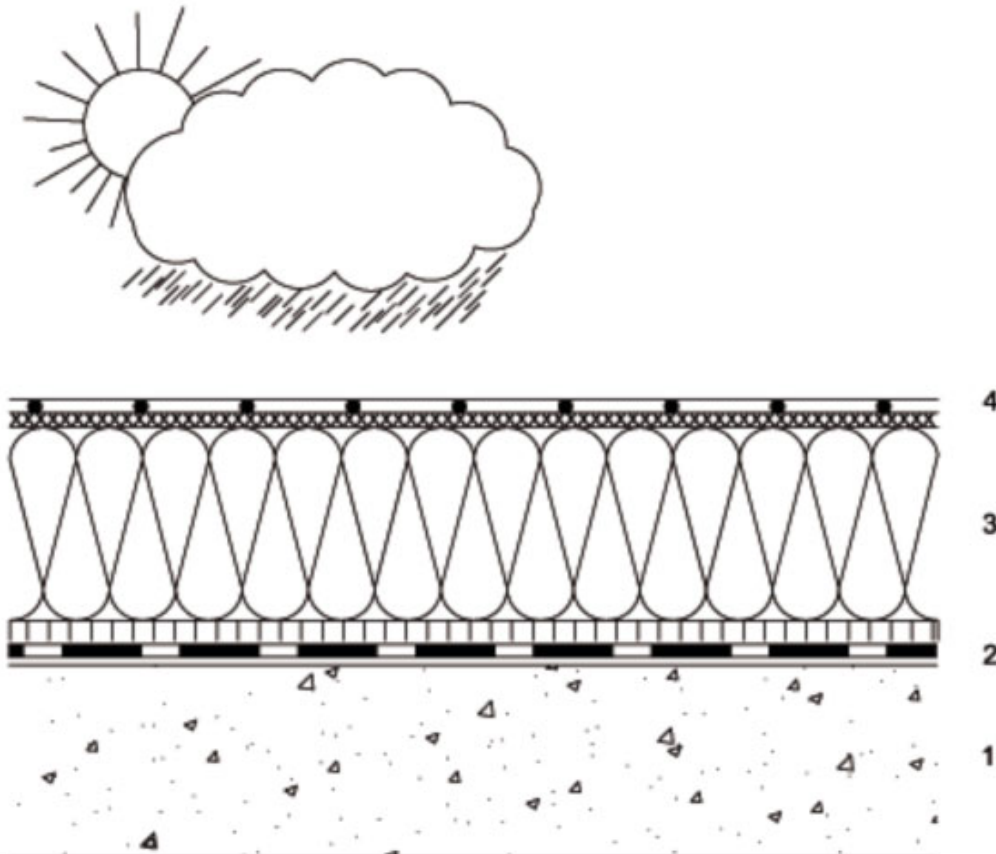

KEY:

1. Substrate
2. Vapour barrier - POLYVAP SA + POLYPRIMER HP 45 PRO primer
3. Fully-bonded insulating layer
4. Waterproof membrane - MAPEPLAN Af (15 - 18)
fully-bonded with MAPEPLAN ADS 100 adhesive

Stratigraphic section of a flat roof

Exposed warm roof with adhered membrane



STRATIGRAPHIC SECTION TPO/FPO N.7.2.A

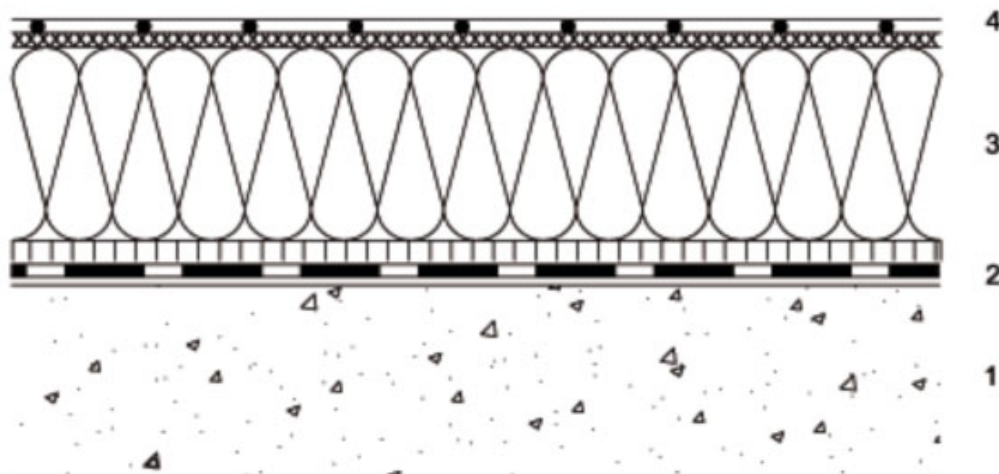

KEY:

1. Substrate
2. Vapour barrier - POLYVAP SA + POLYPRIMER HP 45 PRO primer
3. Fully-bonded insulating layer
4. Waterproof membrane - MAPEPLAN T Af (15 - 18)
fully-bonded with MAPEPLAN ADS 100 adhesive

Stratigraphic section of a flat roof

Exposed warm roof with adhered membrane



STRATIGRAPHIC SECTION PVC-P N.7.2.B

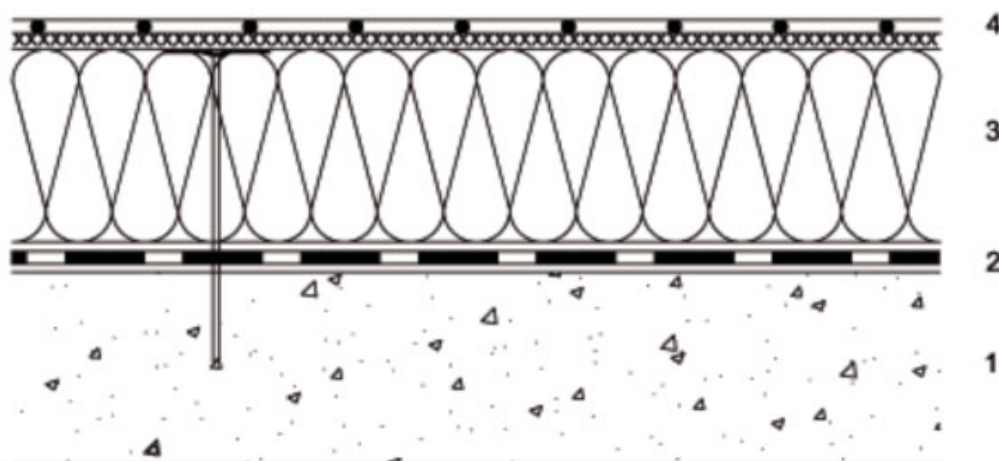

KEY:

1. Substrate
2. Vapour barrier - POLYVAP SA + POLYPRIMER HP 45 PRO primer
3. Mechanically-fixed insulating layer
4. Waterproof membrane - MAPEPLAN Af (15 - 18)
fully-bonded with MAPEPLAN ADS 100 adhesive

Stratigraphic section of a flat roof

Exposed warm roof with adhered membrane



STRATIGRAPHIC SECTION TPO/FPO N.7.2.B

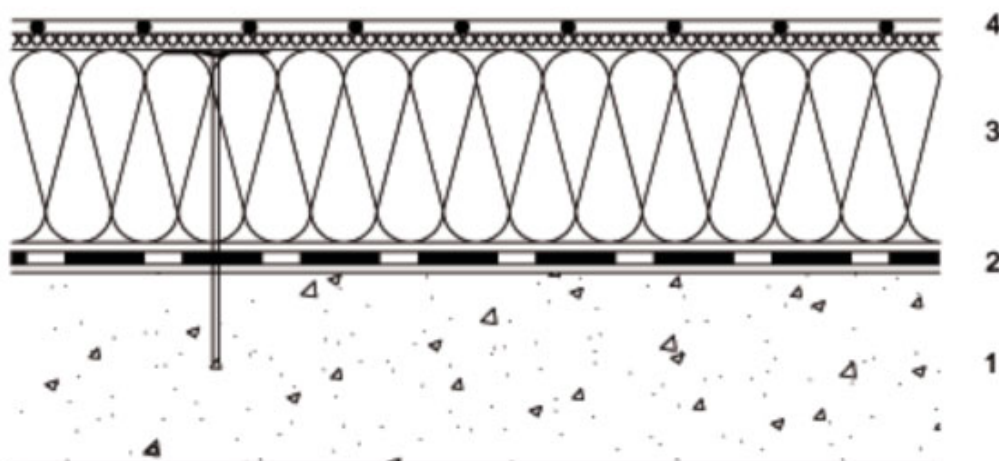
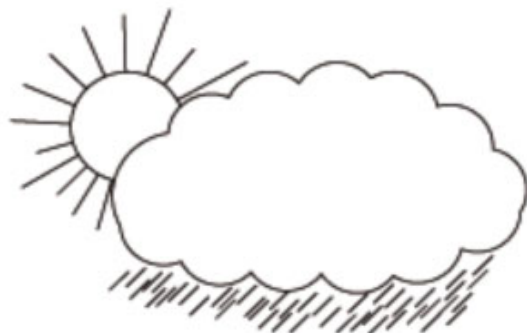

KEY:

1. Substrate
2. Vapour barrier - POLYVAP SA + POLYPRIMER HP 45 PRO primer
3. Mechanically-fixed insulating layer
4. Waterproof membrane - MAPEPLAN T Af (15 - 18)
fully-bonded with MAPEPLAN ADS 100 adhesive

Stratigraphic section of a flat roof

Exposed cold roof with
mechanically-fixed membrane



STRATIGRAPHIC SECTION TPO/FPO N.8.1

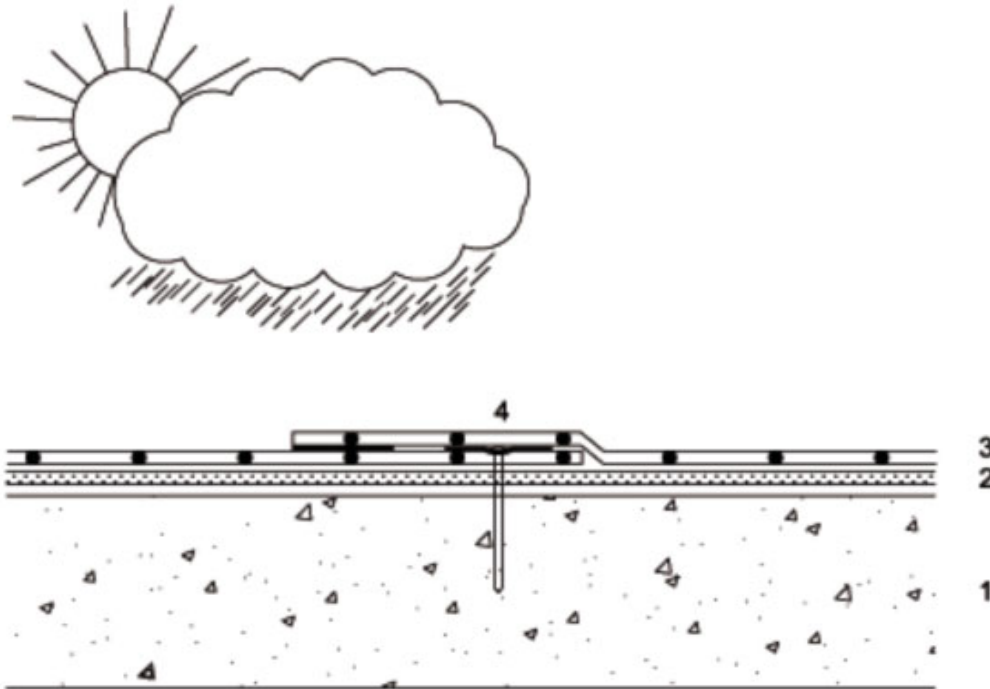

KEY:

1. Substrate
2. Compensation layer - POLYDREN PP
3. Fully-bonded insulating layer
3. Waterproof membrane - MAPEPLAN T M (15 - 18)
4. Mechanical fixing system

Stratigraphic section of a flat roof

Exposed cold roof with
mechanically-fixed membrane



STRATIGRAPHIC SECTION PVC-P N.8.1

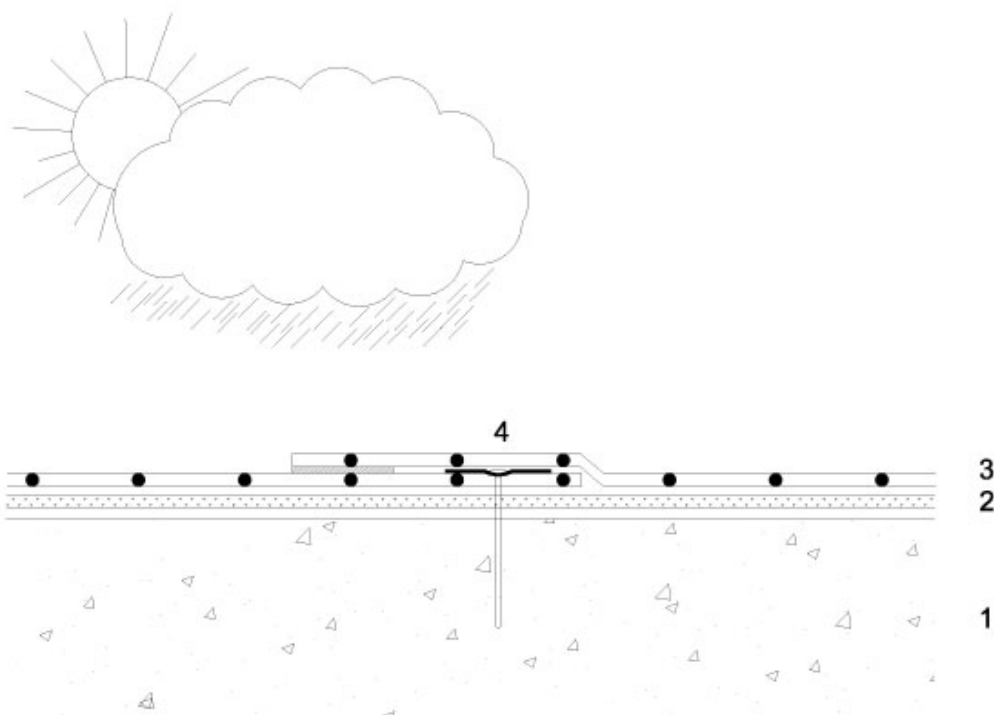

KEY:

1. Substrate
2. Compensation layer - POLYDREN PP
3. Waterproofing membrane - MAPEPLAN M (15 - 18)
4. Mechanical fixing system

Stratigraphic section of a flat roof

Exposed warm roof with mechanically-fixed membrane



STRATIGRAPHIC SECTION PVC-P N.8.2.A

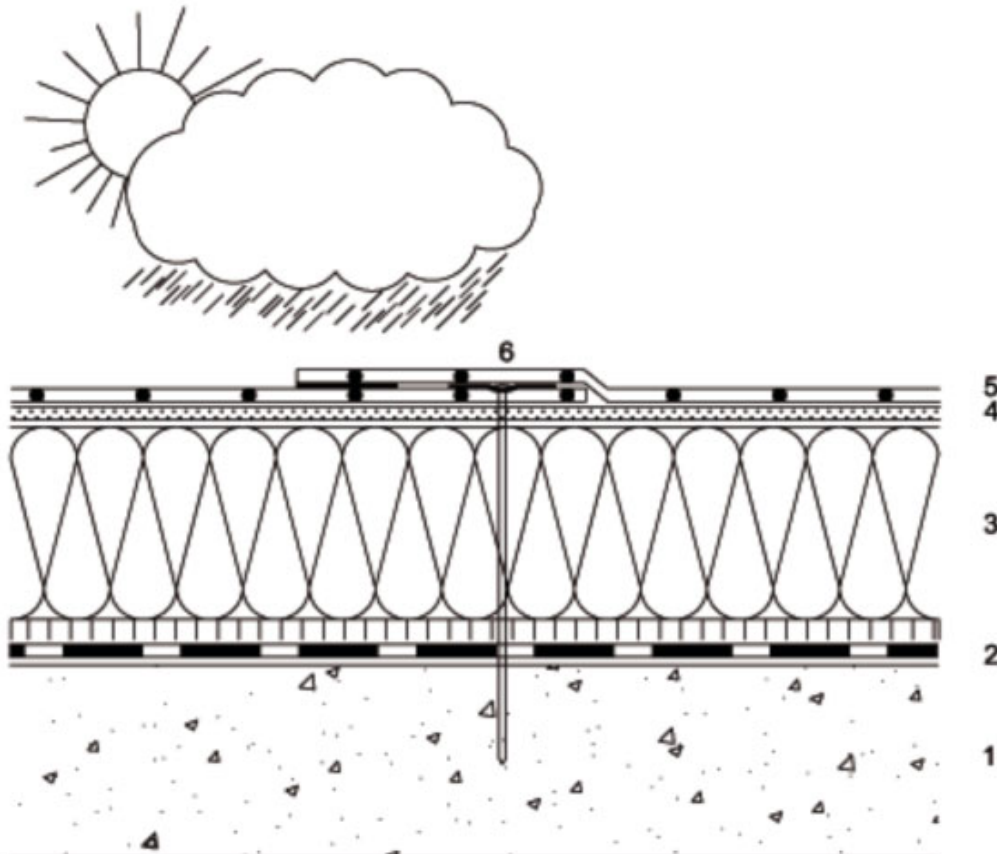

KEY:

1. Substrate
2. Vapour barrier - POLYVAP SA + POLYPRIMER HP 45 PRO primer
3. Mechanically-fixed insulating layer
4. Separation layer - POLYDREN PES 200 (if required)
5. Waterproof membrane - MAPEPLAN M (15 - 18)
6. Mechanical fixing system

Stratigraphic section of a flat roof

Exposed warm roof with mechanically-fixed membrane



STRATIGRAPHIC SECTION TPO/FPO N.8.2.A

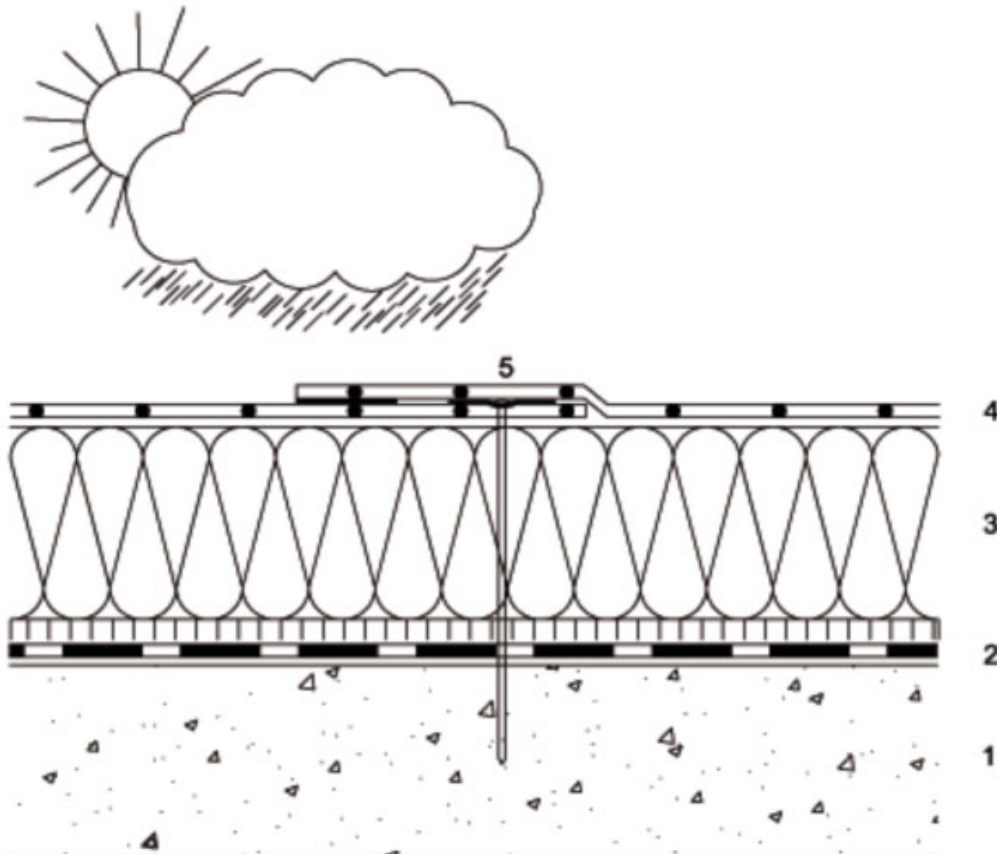

KEY:

1. Substrate
2. Vapour barrier - POLYVAP SA + POLYPRIMER HP 45 PRO primer
3. Mechanically-fixed insulating layer
4. Waterproof membrane - MAPEPLAN T M (15 - 18)
5. Mechanical fixing system

Stratigraphic section of a flat roof

Exposed warm roof with
mechanically-fixed membrane



STRATIGRAPHIC SECTION PVC-P N.8.2.B

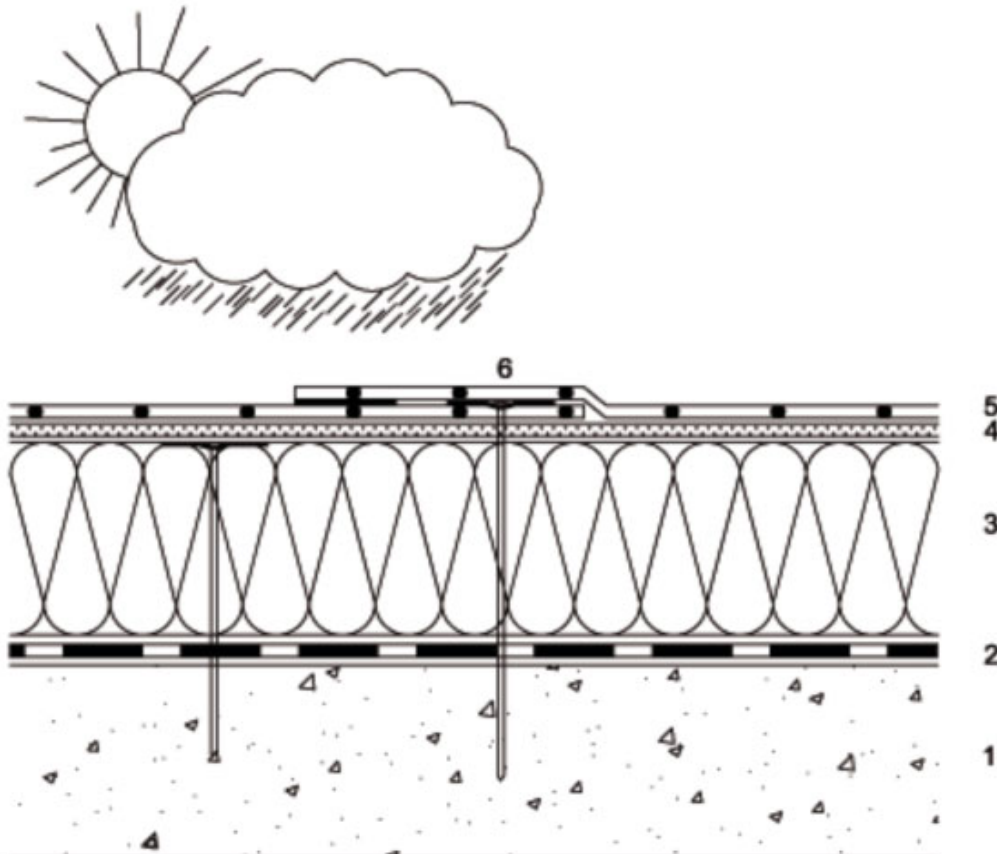

KEY:

1. Substrate
2. Vapour barrier - POLYVAP SA + POLYPRIMER HP 45 PRO primer
3. Mechanically-fixed insulating layer
4. Separation layer - POLYDREN PES 200 (if required)
5. Waterproof membrane - MAPEPLAN M (15 - 18)
6. Mechanical fixing system

Stratigraphic section of a flat roof

Exposed warm roof with
mechanically-fixed membrane



STRATIGRAPHIC SECTION TPO/FPO N.8.2.B

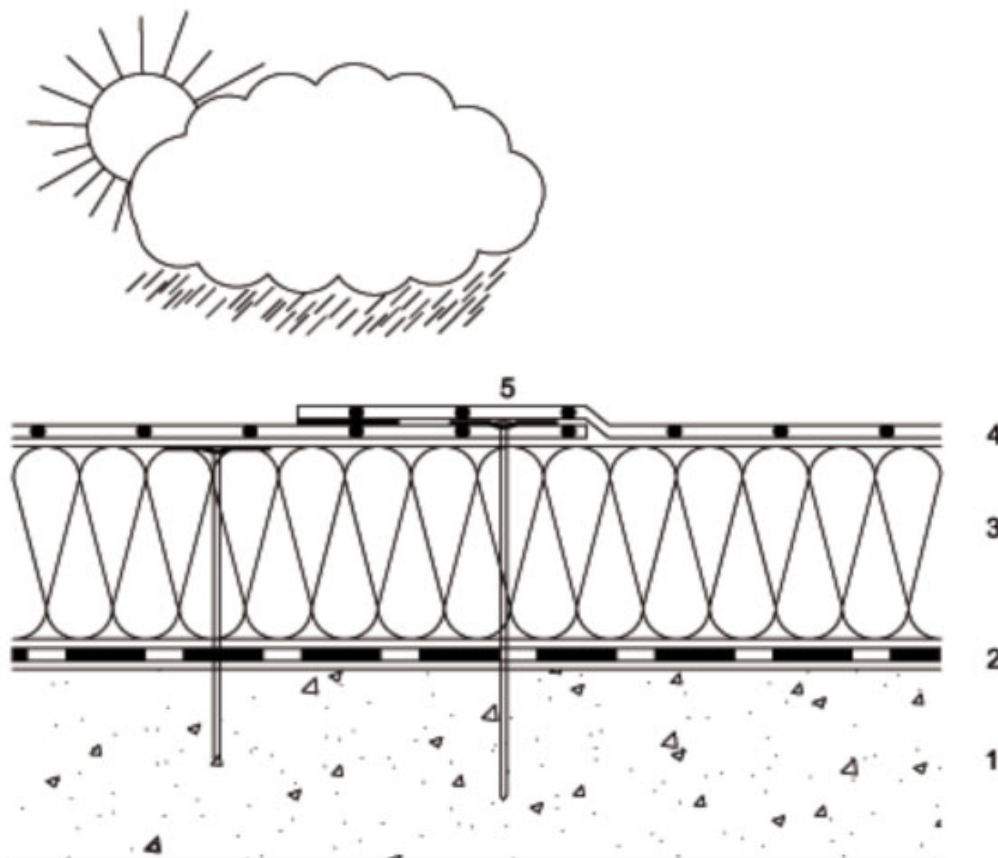

KEY:

1. Substrate
2. Vapour barrier - POLYVAP SA + POLYPRIMER HP 45 PRO primer
3. Mechanically-fixed insulating layer
4. Waterproof membrane - MAPEPLAN T M (15 - 18)
5. Mechanical fixing system

Stratigraphic section of a flat roof

Exposed warm roof with
mechanically-fixed membrane



STRATIGRAPHIC SECTION PVC-P N.8.3

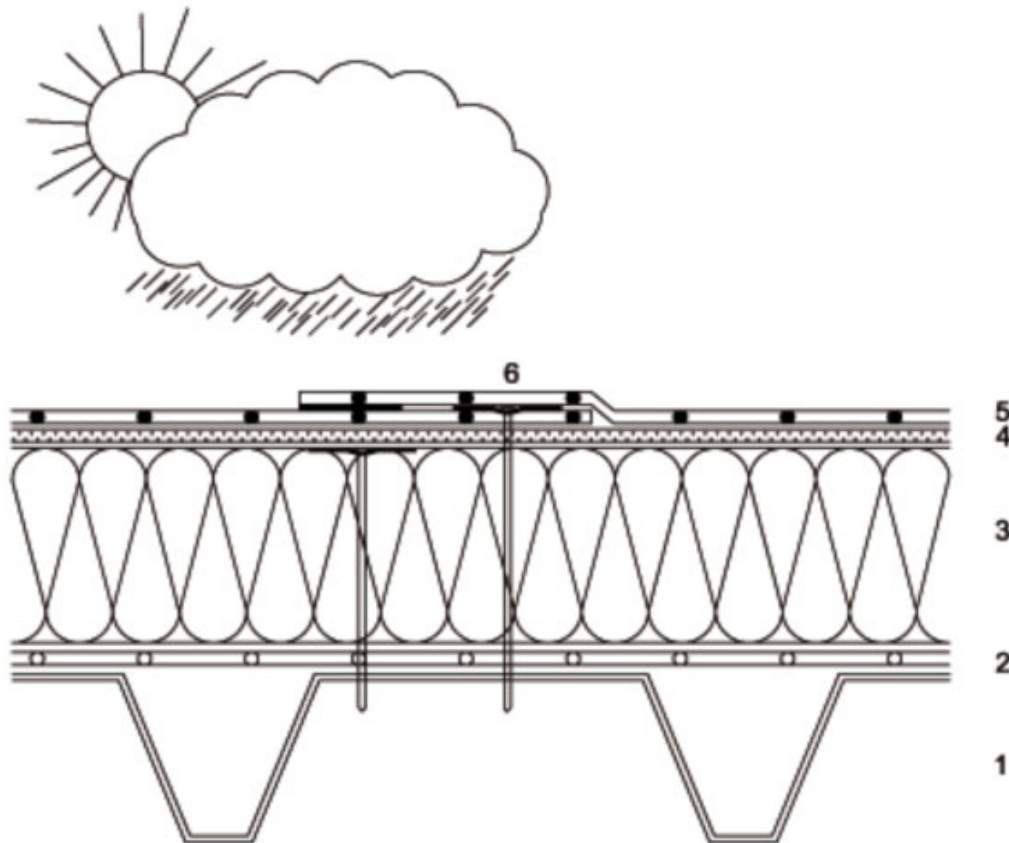

KEY:

1. Substrate
2. Air-tight vapour check/barrier - MAPEPLAN VB PE
3. Mechanically-fixed insulating layer
4. Separation layer - POLYDREN PES 200 (if required)
5. Waterproof membrane - MAPEPLAN M (15 - 18)
6. Mechanical fixing system

29.07.2011

Polyglass reference: Stratigraphic section M13

Stratigraphic section of a flat roof

Exposed warm roof with
mechanically-fixed membrane



STRATIGRAPHIC SECTION TPO/FPO N.8.3

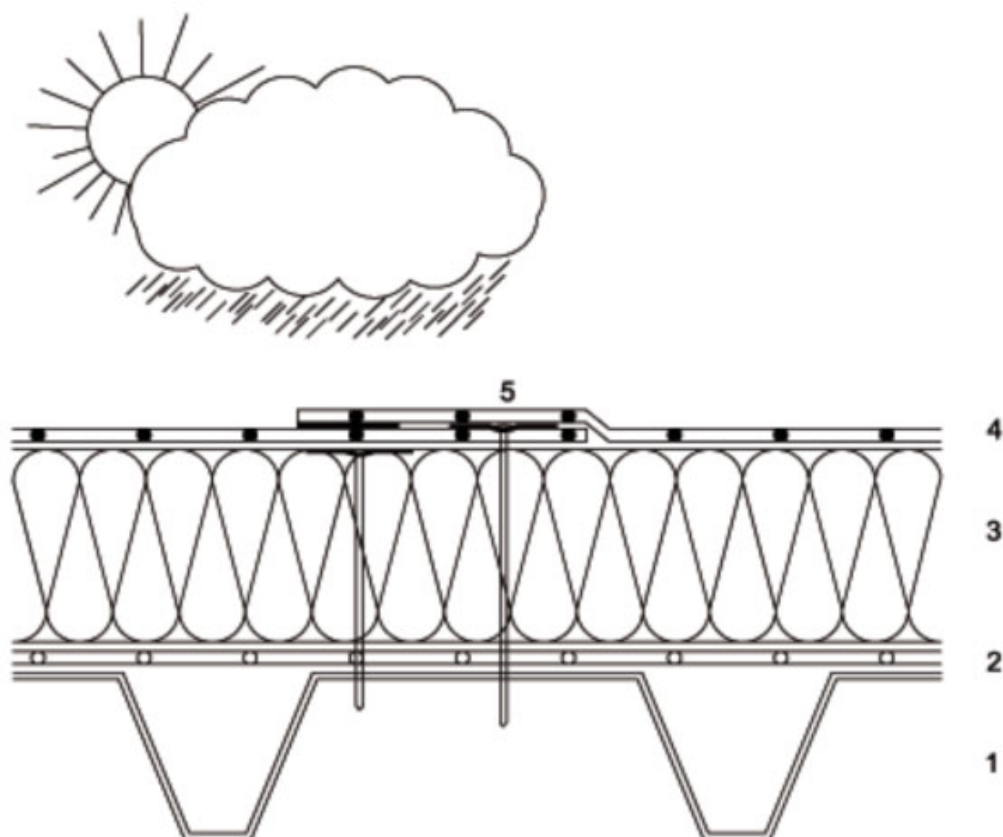

KEY:

1. Substrate
2. Air-tight vapour check/barrier - MAPEPLAN VB PE
3. Mechanically-fixed insulating layer
4. Waterproof membrane - MAPEPLAN T M (15 - 18)
5. Mechanical fixing system

Stratigraphic section of a flat roof

Exposed warm roof with
mechanically-fixed membrane



STRATIGRAPHIC SECTION PVC-P N.8.4

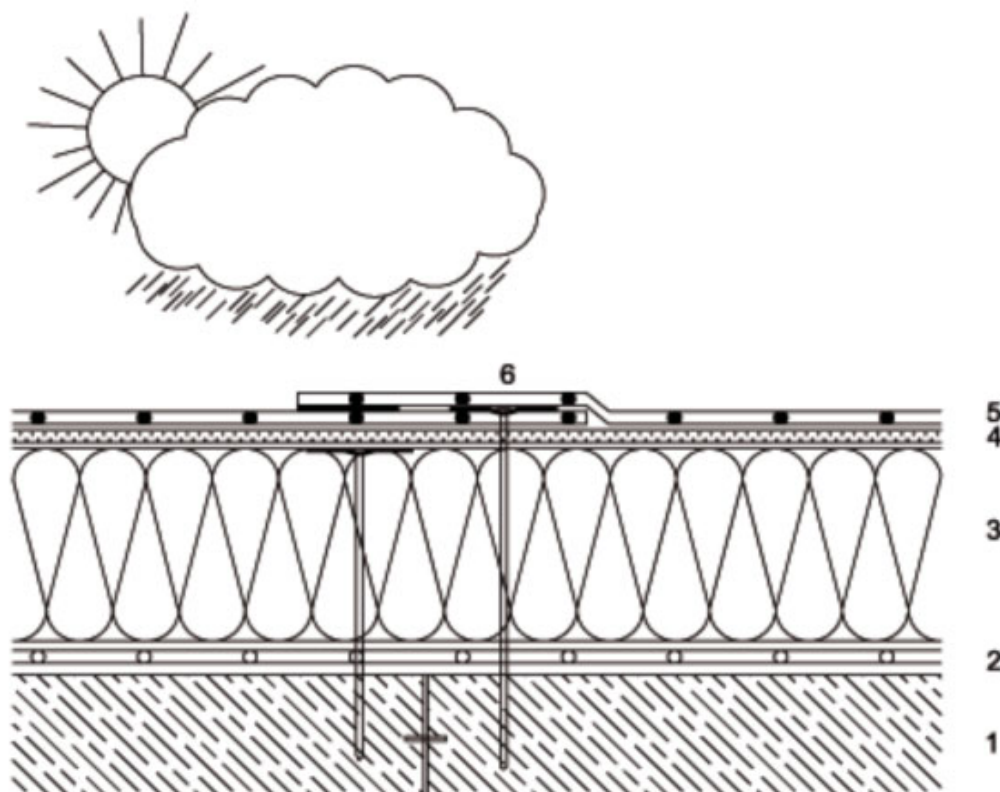

KEY:

1. Substrate – Wooden boarding or planks
2. Air-tight vapour check/barrier - MAPEPLAN VB PE
3. Mechanically-fixed insulating layer
4. Separation layer - POLYDREN PES 200 (if required)
5. Waterproof membrane - MAPEPLAN M (15 - 18)
6. Mechanical fixing system

Stratigraphic section of a flat roof

Exposed warm roof with
mechanically-fixed membrane



STRATIGRAPHIC SECTION TPO/FPO N.8.4

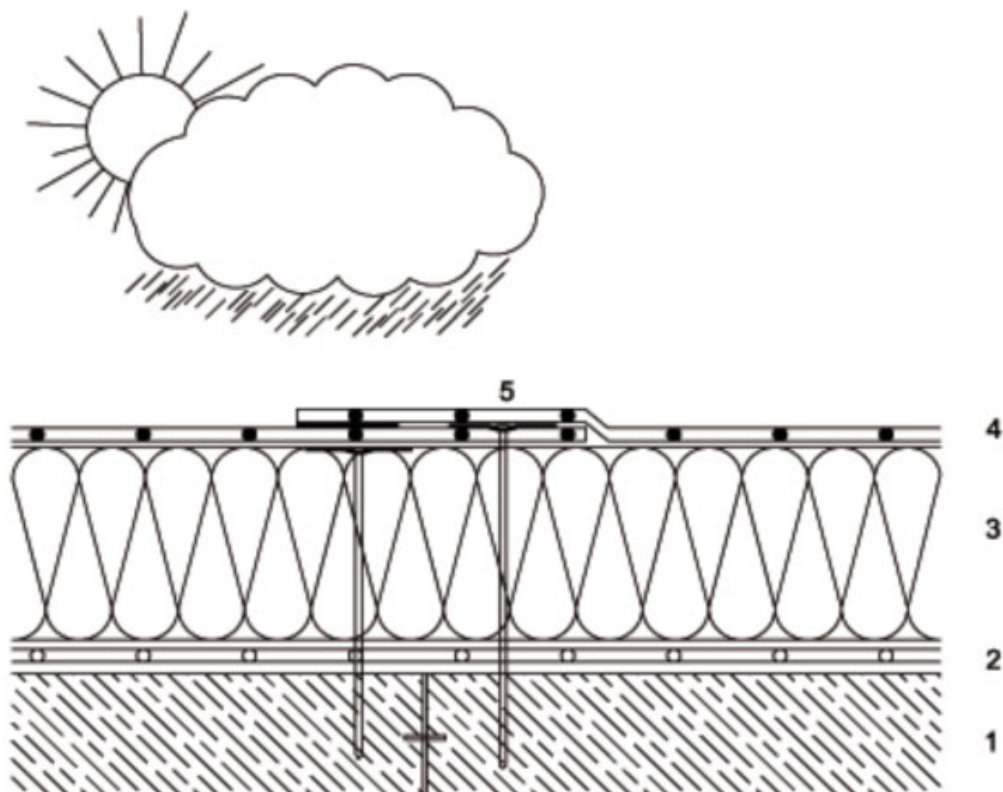

KEY:

1. Substrate – Wooden boarding or planks
2. Air-tight vapour check/barrier - MAPEPLAN VB PE
3. Mechanically-fixed insulating layer
4. Waterproof membrane - MAPEPLAN T M (15 - 18)
5. Mechanical fixing system